

OPI DATE 29/03/99 APPLN. ID 92536/98
AOJP DATE 27/05/99 PCT NUMBER PCT/DE98/02758



AU9892536

(51) Internationale Patentklassifikation⁶ : B29B 17/00, B26D 1/00, B29L 30/00, B09B 3/00	A2	(11) Internationale Veröffentlichungsnummer: WO 99/12717 (43) Internationales Veröffentlichungsdatum: 18. März 1999 (18.03.99)
(21) Internationales Aktenzeichen: PCT/DE98/02758 (22) Internationales Anmeldedatum: 10. September 1998 (10.09.98) (30) Prioritätsdaten: 197 40 413.8 10. September 1997 (10.09.97) DE (71)(72) Anmelder und Erfinder: SCHMELING, Burkhard [DE/DE]; Am Marienberg 18, D-15344 Strausberg (DE). (74) Anwälte: HENGELHAUPT, Jürgen, D. usw.; Lützowplatz 11-13, D-10785 Berlin (DE).	(81) Bestimmungsstaaten: AL, AM, AT, AU, AZ, BA, BB, BG, BR, BY, CA, CH, CN, CU, CZ, DK, EE, ES, FI, GB, GE, GH, GM, HR, HU, ID, IL, IS, JP, KE, KG, KP, KR, KZ, LC, LK, LR, LS, LT, LU, LV, MD, MG, MK, MN, MW, MX, NO, NZ, PL, PT, RO, RU, SD, SE, SG, SI, SK, SL, TJ, TM, TR, TT, UA, UG, US, UZ, VN, YU, ZW, ARIPO Patent (GH, GM, KE, LS, MW, SD, SZ, UG, ZW), eurasisches Patent (AM, AZ, BY, KG, KZ, MD, RU, TJ, TM), europäisches Patent (AT, BE, CH, CY, DE, DK, ES, FI, FR, GB, GR, IE, IT, LU, MC, NL, PT, SE), OAPI Patent (BF, BJ, CF, CG, CI, CM, GA, GN, GW, ML, MR, NE, SN, TD, TG). Veröffentlicht <i>Ohne internationalen Recherchenbericht und erneut zu veröffentlichen nach Erhalt des Berichts.</i>	
(54) Title: METHOD AND DEVICE FOR PROCESSING TIRES (54) Bezeichnung: VERFAHREN UND VORRICHTUNG ZUM VERARBEITEN VON REIFEN (57) Abstract The invention relates to a method for processing tires, producing products comprised of the tire material and a device for cutting tires and flatly constructed products or bodies e.g. blocks, mats or cords which are produced from cut tires. The invention can be applied especially to reshaping passenger car, truck or aircraft tires that are no longer acceptable for use in transportation into a new foundation as a base material which can be utilized for manufacturing products in multiple areas of the economy. Intermediate products for manufacturing new final products are made out of cut tire rings. The method is characterized in that the tires are separated into a series of segments in such a way that the two side pieces of the wheel tread are separated off and the resulting rings are joined to form new products with one another. (57) Zusammenfassung Die Erfindung beschreibt ein Verfahren zum Verarbeiten von Reifen und zur Herstellung von aus dem Reifenmaterial bestehenden Produkten, eine Vorrichtung zum Schneiden von Reifen sowie Flächengebilde oder Körper, beispielsweise Blöcke, Matten oder Stränge, welche aus den geschnittenen Reifen hergestellt sind. Die Erfindung ist anwendbar insbesondere zur Umformung von nicht mehr verkehrstechnisch verwertbaren PKW-, LKW- oder Flugzeugreifen in einen neuen Grundbaustein, der als Ausgangsmaterial für die Herstellung von Produkten in vielfältigen Bereichen der Wirtschaft eingesetzt werden kann. Zwischenprodukt für die Herstellung neuer Endprodukte sind aus den Reifen geschnittene Ringe. Das Verfahren ist dadurch gekennzeichnet, daß die Reifen durch eine Aufeinanderfolge von Schnitten zerlegt werden derart, daß die zwei Seitenteile von der Lauffläche abgetrennt werden und die entstehenden Ringe zu neuen Produkten miteinander verbunden werden.		

Method and device for Processing Tires

Description

5 The objective of the invention relates to a method for the processing of tires and for the manufacture of products comprised of the tire material, to a device for cutting up tires as well as construction of interwoven mesh structures or bodies such as blocks, hollow bodies, mats or aligned units manufactured from the cut-up tires.

10 The invention is particularly applicable to the conversion of used tires, non-recyclable for traffic purposes, arising from motor cars, road haulage trucks and aircraft, into a new basic construction element which can be used for the manufacture of a wide scope of commercial products. Inter-
15 mediates for the manufacture of new end-products are rings cut out of the tires.

Comminution of tires no longer permissible for use as such, by means of shredders for example, with subsequent use of the fragments as aggregate material, in cement production
20 or as fillers in road construction substrates for example, is well known. Further application possibilities for discarded tires are incineration and thus the production of heat energy, chemical decomposition into raw products or deposition on dumping grounds.



Of disadvantage in the known application possibilities is that the said possibilities only permit recycling after loss of quality, raw material or characteristic properties. Centralization of the application can only proceed via
5 transportation of the tires without reduction of their volume.

Patent No. DE 39 33 729 A1 describes a process for recycling discarded tires wherein the tires are cut up to form endless ribbons. The array of utilities of such endless
10 ribbons is relatively limited.

In Patent No. DE 33 086 51 A1 a network of tire shaped bodies is described wherein the tires are not cut into narrower slices or are arranged in cut form into rings or strips.

15 The disadvantage of this solution is that additional fastening elements such as rivets, clasps or pins are necessary for the interconnection of rings produced from tires.

In patent No. DE 42 009 49 A1 a method and device for the dismemberment of discarded tires is described wherein a
20 fixed rotationally driven tire is cut into slices by means of adjustably arranged cutters on the outside face, resulting in production of the running tread of the tire, two tire walls and two wheel rim beads.



The invention has an objective of providing a method and a device by means of which effective reprocessing of a wide variety of tires is possible and intermediates for new end products with high user quality can be manufactured in simple ways at attractive prices.

A further objective of certain embodiments of the invention is to demonstrate a new range of applications and utilization of the end products.

10

The said objectives are addressed according to one aspect of the invention by a method for processing tires and the manufacture of products composed of tire material wherein the tires are dismembered by a sequence of cuts, said method characterized in that the two side walls are separated from the running tread and the rings arising are combined together to new products by means of a weaving process.

15

In another aspect of the invention, there is provided a block, hollow body, mat or aligned units consisting of interwoven rings from cut up tires. Such blocks, hollow bodies, mats or aligned units find many uses, including those set out in claim 14.

20



A particular advantage of the invention is that the conversion of the tires into intermediate product rings is a fully environmentally friendly production method, in the process of which no waste accrues and no pollutants are discharged, and wherein the tires are dismembered by a sequence of cuts in such a way that the two side walls are separated from the running tread and the rings arising from the side walls and/or running tread are combined together to form new products. The rubber-cased metal ring ensuring firm seating of the tire on the wheel rim can also be recycled.

All tires which cannot be fully remolded, are not deformed and have not been cut open transverse to the tread can be used for the method in terms of the invention. The method enables conversion of tires wherever they accumulate.

A further advantage of the invention exists in the fact that the elasticity of the rings retains its proportional share of the strength associated with the tire, production of the rings being such that the tire is fixed to a holding facility and rotated by a drive roller which produces an internal swelling and is aligned with a shaft possessing at least one cutting blade which cuts through the running tread of the tire from the inside.

The surface area and volume of the mass to be transported is reduced to material volume or unit weight respectively by the ring form created. In its new form, i.e. as rings, the tire is transportable without occupying the former volume of a complete tire. The rings created can be compressed to any desired two and three dimensional form permitted by the ring created.



The rings in suitable form can be stacked and transported. If the rings are to be transported to permanently installed cutting facilities or another recycling facility, it is advantageous for the purpose of saving transport space to
5 slit the tires parallel to the middle of the running tread in such a way that two U-shaped parts result which can be stacked inside each other.

The invention is explained hereinafter as several exemplary embodiments, part of which at least is shown in the Fig-
10 ures.

Fig. 1 shows a stylized view of the steering of the cut in a tire represented as a half,

Fig. 2 shows the products of the cut steering as represented in Fig. 1,

15 Figs. 2A
to 2C show variants of the cutting devices,

Fig. 3A shows the formation of a ring chain,

Fig. 3B shows the formation of a interwoven material

Fig. 3C shows the construction of a basic element
20 (four-component element)

Fig. 3D shows the construction of a basic element
(three-component element)



- Fig. 3E shows the formation of a mesh from basic elements according to Fig. 3C,
- Fig. 3F shows the formation of a mat from basic elements according to Fig. 3C,
- 5 Fig. 3G shows the formation of a three-dimensional body from basic elements according to Fig. 3C,
- Fig. 3H shows the formation of a rounded body from basic elements according to Fig. 3C,
- Fig. 3K shows a cutout of initially interwoven mat,
- 10 Fig. 3L shows a woven bag,
- Fig. 3M shows a woven tubular hollow body with a bottom,
- Fig. 3N shows a cutout of a second interwoven mat,
- Fig. 3O shows a cutout of a third interwoven mat,
- 15 Figs. 3P to 3U show further variants of interweaving for construction elements such as aligned units, mats and three-dimensional bodies for example,
- Fig. 4 The arrangement of bodies for the construction of dikes
- 20



- Fig. 5 shows the arrangement of mats as river bank protection,
- Fig. 6 shows the arrangement of mats on the bed of a body of water,
- 5 Fig. 7 shows the arrangement of hollow bodies filled with bulk material for the construction of artificial dams,
- Fig. 8 shows the arrangement of hollow bodies filled with water for the construction of artificial dams,
- 10 Fig. 9 shows the lining of a dam with interwoven mats,
- Fig. 10 shows the reinforcement of a bank with interwoven mats,
- Fig. 11 shows the construction of fascines for bank protection,
- 15 Fig. 12 shows the offsetting of depressions on the bed of a body of water by covering with a mat,
- Fig. 13 shows the offsetting of depressions on the bed of a body of water by filling out with mats,
- 20 Fig. 14 shows the covering of underwater reefs with mats,
- Fig. 15 shows the demarcation of fishery areas constructed with mats,



- Fig. 16 shows the arrangement of mats for the protection of coral banks,
- Fig. 17 shows the arrangement of mats for protection in lock flooding basins,
- 5 Fig. 18 shows the arrangement of mats for protection against the breakthrough of ice sheets,
- Fig. 19 shows the arrangement of mats in pools,
- Fig. 20 shows the arrangement of mats in rivers,
- Fig. 21 shows the arrangement of mats as breakwaters,
- 10 Fig. 22 shows the arrangement of interwoven bodies as breakwaters,
- Fig. 23 shows the arrangement of interwoven bodies as absorbers of undercurrents,
- Fig. 24 shows the arrangement of interwoven bodies for
15 quay protection,
- Fig. 25 shows the arrangement of interwoven bodies for the protection of structures/buildings,
- Fig. 26 shows the arrangement of interwoven bodies or mats for the protection of bridge piers,
- 20 Fig. 27 shows the arrangement of interwoven bodies or mats for the protection of bridge piers and similar structures,



- Fig. 28 shows the arrangement of interwoven bodies as protection against shifting ice,
- Fig. 29 shows the deployment of mats or interwoven bodies as filters,
- 5 Fig. 30 shows the deployment of mats or interwoven bodies as protection against falls over the edge,
- Fig. 31 shows the deployment of mats or interwoven bodies as protection of the outside hull of ships,
- Fig. 32 shows the deployment of mats for earth stabilization,
- 10 Fig. 33 shows the deployment of mats for plant protection,
- Fig. 34 shows the deployment of mats for the construction of reservoir dams,
- 15 Fig. 35 shows the deployment of mats or bodies as avalanche protection,
- Fig. 36 shows the deployment of mats or bodies in the foundations of buildings,
- Fig. 37 shows the deployment of mats for the construction of reservoir dams or bodies as road substrata,
- 20 Fig. 38 shows the deployment of mats for lining pipe or cable shafts,
- Fig. 39 shows the deployment of mats or bodies as protective elements during explosions,
- 25



- Fig. 40 shows the deployment of mats for the prevention of falling rocks,
- Fig. 41 shows the deployment of mats or bodies for the construction of shelters in earthquake zones,
- 5 Fig. 42 shows the deployment of mats for the protection of bunkers,
- Fig. 43 shows the deployment of mats in connection with protective barriers,
- Fig. 44 shows the deployment of mats as traffic guid-
10 ance and crash protection in road traffic,
- Fig. 45 shows the deployment of mats for drainage purposes,
- Fig. 46 shows the deployment of mats for fencing purposes,
- 15 Fig. 47 shows the deployment of mats as load distribution elements,
- Fig. 48 shows the deployment of mats for tree protection,
- Fig. 49 shows the deployment of mats for silage cover-
20 age,
- Fig. 50 shows the deployment of mats for landfill demarcation,
- Fig. 51 shows the deployment of mats for raised access routes,



- Fig. 52 shows the deployment of fire mats for burnt aisle counteraction against fires,
- Fig. 53 shows the deployment of mats for lightning protectors and vehicle shelters,
- 5 Fig. 54 shows the deployment of mats for laying out paddy fields,
- Fig. 55 shows the deployment of mats for road marking,
- Fig. 56 shows transportation possibilities for mats and/or bodies respectively,
- 10 Fig. 57 shows the deployment of mats for the construction of safety cages in space.

As shown in Fig. 1, a tire is cut in such a way that a running tread ring 1 and two side wall rings 2, are obtained. The running tread ring 1 and side wall rings 2 are shown in
15 Fig. 2.

The running tread ring 1 can be dismembered into narrower rings by further cuts, just as can the side wall rings 2. Figs. 2A to 2C show variants of the cutting devices.

The tire 3 is fixed in a holding facility or guide 4 or unsupported and rotated by a transversally arranged drive roller 5 and is laterally guided. The cutting blade 8 swings inside against the swelling 7 induced by the drive roller and cuts the tire 3 into at least 2 annular parts. The cutting edges are arranged in such a way that the rubber is tensioned against them during the process of cutting.
20
25
Deposition of the halves of the tire as shown in



Fig. 2C occurs on both sides, on top of each other and held together by suitable means. By using multiple cutter systems, several cutters 8 are variably adjustable on the shaft 6 in terms of their distance apart. Several rings of the same or different widths can be prepared from the running tread 1 of the tire 3 by this means. Removal of the rings from the cutting system into the stacking unit is effected by grasping elements. Stabilization of the cutting process is achieved by clamping the wheel rim beading in a receptive device. Any mechanical procedures as well as computer aided positioning techniques can be used. Cutting up the tires using a cutter 8 from the outside is also possible.

Creation of interwoven mesh structures or three-dimensional bodies is performed by joining the rings up by hand or by means of handling manipulators or clamping/gripping elements. Combination of the rings by hand is performed by gripping a ring and pressing it together in such a way that equivalent sized loops are formed to the left and right.

Passage of a folded further ring through the two loops or openings makes it possible to grasp the loops of the second ring. Opening of the starting ring is prevented by fixation with the result that a new ring can be passed through the newly created loops. The weaving process described can be supported by devices diverting the weave created away from the amenity such that a continuous production process proceeds with the weaving equipment.

Several embodiments of the interwoven mesh structures and bodies obtainable from weaving are shown in Figs. 3A to 3H. Mats which can be used for the reinforcement of dikes



against the influence of swollen waters for example are very effectively produced interwoven patterns.

Figure 3A shows the creation of a ring chain where the individual rings are knotted together. Figure 3B shows the
5 creation of an interwoven mesh. Figure 3C represents the construction of a four-component basic element, figure 3D that of a three-component basic element. Figure 3E shows the creation of a mesh structure out of basic elements of type 3C. Figure 3F shows the construction of a mat, figure
10 3G the construction of a rectangular three-dimensional body, and figure 3H that of rounded bodies. Figure 3K represents a cutout of an interwoven mat. Figure 3L shows a woven bag which can serve as a container for hardcore for example. Figure 3M represents a tubular hollow body closed
15 at one end by a rounded bottom. Figure 3N shows a cutout of a second interwoven mat and figure 3O a cutout of a third interwoven mat. Figures 3P - 3U show further weaving variants providing construction elements for roping, mats and three-dimensional bodies for example.



A variety of different applications for new products manufactured by interweaving a series of closed rings is described hereinafter. Figure 4 shows the construction of dams exhibiting filled hollow bodies 13 or interwoven bodies 25 in their interior. Stabilization of the dam structure results from hollow bodies 13, interwoven bodies 25 or the incorporation of mats 9, with the effect that the dam can stand up to greater loads than if merely constructed of earth 15.

Figure 5 shows the incorporation of mats as bank protective measures, where two overlapping mats 9 are arranged in the present embodiment. The mats 9 are let into the bank 10, redistributing the pressure generated by the water 11 over the mats 9 and protecting the bank 10 against alluvial deposition and undermining erosion. This protective measure can be applied both for canals and natural banks.

Figure 6 shows the arrangement of mats 9 on the bed of a body of water 12 preventing the scouring away of sand for example and the generation of underwater potholes/channels in the bedding. Figure 7 represents hollow bodies filled with bulk material such as sand which can be installed as artificial dams of any desired length, height and width in the water 11. A further construction form of hollow bodies 13 is shown in figure 8 where the hollow bodies 13 are filled with water 11. To avoid the water escaping through the interstices of the woven structure the hollow bodies are lined with a waterproof sheeting 14.



Figure 9 shows the lining of a dam with woven mats 9 where the dam lining is covered with earth 15 and the dam exhibits a counter-shaft 16 which is also lined by the mats 9. Figure 10 represents a simplified form of bank reinforcement consisting of woven mats 9 where the mats 9 are partially let into the earth both in the water and on the bank. Figure 11 shows the construction of fascines for bank protection where the rings 1 act in conjunction with stakes 17. Figures 12 and 13 show the offsetting of depressions on the bed of a body of water by covering with a mat. With regard to the embodiment exemplified in figure 12, the depression 18 is covered over with a mat 9, whereas in the embodiment exemplified in figure 13 the depression is filled out with mats 9. Figure 14 represents the covering over of underwater reefs 19 with mats 9. This measure serves to protect watercraft against collision.

Figure 15 shows practical implementation of the demarcation of fishery areas where mats 9 provide the said demarcation of the bodies of water. Fish can be effectively reared within the confines of the body of water separated by the mats 9. Figure 16 shows the arrangement of mats 9 for the protection of coral banks.

Figure 17 represents an exemplary application where the internal space of lock flooding basins is lined with mats 9. The mat 9 may serve for the recovery and security of vessels such as sports boats for example. Figure 18 represents the application of mats as protection against the breakthrough of ice sheets. The mats 9 are attached to buoys 22 anchored below the surface of the water. If the water freezes over with an ice sheet 23, the protective



system of mats 9 and buoys 22 is situated below the surface of the ice. If a person should break through the ice 23, the said person will be protected against submersion and/or drowning by the mats 9.

5 The arrangement of mats according to figure 19 serves the purpose of removing refuse from ponds, for example fire department reservoir-pools by means of raising the mats 9. Figure 20 represents the application of mats 9 in rivers 24 in which the mats are incorporated as linings on the bed of
10 the river. The said lining prevents any erosion of the bedding and deposition of sediment.

Figures 21 - 23 show the arrangement of mats 9 or interwoven bodies 25 respectively as wave absorbers or breakwaters. The mats 9 or interwoven bodies 25 respectively are
15 arranged entirely or partly underwater. Figure 24 represents an exemplary embodiment in which the interwoven bodies are arranged for the protection of quay facilities. The interwoven bodies can act in conjunction with buoys 22, be anchored on the bed 12 of the body of water or be permanently fixed in the bed 12. Figure 25 is a general representation of the protection of structures/buildings by interwoven bodies 25. Mats 9 may also be used instead of the
20 interwoven bodies 25. Selected structures in the present embodiment are buildings which are to be protected from contact with an excavator, or water engineering facilities such as harbors or bridges. The special protection of
25 bridge piers 28 is represented in figure 26 where the bridge pier 28 is encased by mats 9 in this case. A further exemplary embodiment for the protection of bridge
30 piers 28, arches and dams against damage is represented in



figure 27. The application is achieved either by mats 9 in conjunction with buoys, or by interwoven bodies 25. The interwoven bodies 25 or mats 9 respectively are arranged in front of the bridge piers 28. Figure 28 shows the arrangement of interwoven bodies 25 in water for protection against ice shifting during breakup on rivers, lakes and the sea. The masses of ice are intercepted by interwoven bodies so that damage can be avoided. The use of mats 9 or interwoven bodies 25 as filters is represented in figure 29. For example, the mats 9 can be drawn through the water 11 by a boat 31 in order to pick up waste matter in the net structure of the mats 9. It is equally possible to introduce mats 9 into sewage treatment tanks 29 to pick up waste matter. A further possible application of the mats 9 consists in arranging the said mats in front of the entry into the collecting basins so that waste matter is filtered out. An arrangement of mats 9 or interwoven bodies 25 as active protection of persons or animals is represented in figure 30. The mats 9 or interwoven bodies 25 prevent possible falls over the edge. The arrangement of mats 9 on the outside hull of a ship protects the outer hull from mechanical damage. The use of mats 9 for earth stabilization is represented in figure 32. A special field of application is the securing of slopes, where either a single mat 9 or several mats 9 arranged over one another can be deployed. Figure 33 represents the use of mats 9 for plant protection. The earth surface is laid out with mats 9 and the plants/shoots located in the interstices of the woven structure. Figure 34 shows the use of mats 9 for constructing dams and overflow basins for water arising from swollen rivers. The mat 9 is laid out in a trench and sta-



bilizes the dike of the overflow basin. As an alternative to the construction of overflow basins the dams stabilized by means of the mats 9 can also be used to construct saline recovery basins. Figure 35 shows the application of mats 9 or interwoven bodies 25 as avalanche protection. The mats 9 and/or interwoven bodies 25 are arranged on the slope 33 and serve to intercept avalanches. Figure 36 shows the use of mats 9 or interwoven bodies in the foundations of buildings. It is possible to stabilize both strip foundations and full surface foundations by the use of mats 9 or interwoven bodies 25. Figure 37 represents the arrangement of mats 9 as road construction substrate. The mats 9 are arranged under the road 34. Instead of roads 34, pathways and open spaces, particularly playing fields, can also be stabilized by use of mats under the ground. Figure 38 shows the application of mats 9 for lining pipe or cable shafts. The pipes 35 or cables 36 respectively are bedded into the mats 9 and covered by overlaps if required. The application of mats 9 or interwoven bodies 25 as protective elements during explosions is represented in figure 39. Thus, the mats 9 can be deployed as bomb protection mats or arranged for use during the detonation of ammunition findings. It is also possible to deploy staggered arrangements of interwoven bodies 25 as protective elements during blasting operations. In order to limit the evacuation radius during defusing/removal of unexploded bombs or minimize the effect of shrapnel on detonation, the said bombs or other explosive ammunition findings can be covered by mats 9 or interwoven bodies 25.



Prevention of falling rocks is served by the arrangement of mats 9 as represented in figure 40. The use of mats 9 or interwoven bodies 25 for the construction of shelters, in earthquake zones for example, is represented in figure 41.

5 Dugout shelters or bunkers as shown in figure 42 can be constructed using mats 9 or interwoven bodies 25. The external surfaces of bunkers 38 can be dammed by mats 9. Dugout shelters in mountainous regions can be constructed as before using mats 9 and/or interwoven bodies 25, which

10 also offer protection against lightning. The aforementioned results from the Faraday cage effect of metallic components of the weave.

Fig. 43 shows the deployment of mats 9 in conjunction with protective barriers. The mats 9 are arranged in such a way

15 that they form an interceptive possibility for vehicles coming off the road. Damage to the vehicles is minimized by the elasticity of the mats 9. Fig. 44 shows the deployment of interwoven bodies 25 or mats 9 as traffic guidance elements and crash protection in road traffic. The said

20 elements are primarily arranged parallel to the road 34 in the region of curves. Fig. 45 represents the use of mats for drainage purposes next to the road 34. The mats are rolled up in the present embodiment and thus achieve the drainage function. In Fig. 46, the mats 9 are used as

25 fences and serve to separate areas from humans and animals. Fences of this kind are also applicable against snowdrifts or accumulations of other material, in the proximity of landfills for example. Fig. 47 shows an application variant as load redistribution elements. Use of the mats 9 ef-

30 fects a redistribution of the loading and reduction of the



pressure on the ground when freight is set down. The application of mats 9 as shown in Fig. 48 is suitable for the protection of trees. Thus on the one hand, the trunks of the trees can be protected by envelopment in mats 9, and on the other hand, the root area by laying out mats 9. The use of mats 9 for covering silage heaps is as shown in Fig. 49. The contents of the silage heap is covered over with mats 9, resulting in protective coverage on the one hand and weighting on the other hand. The deployment of mats 9 for landfill demarcation is represented in Fig. 50. Mats 9 are arranged both underneath and above the body of the waste 43, on the one hand covering the body of the waste 43, and on the other hand delimiting the said waste 43 against the surrounding earth. The arrangement of mats 9 according to Fig. 51 is suitable for the construction of chronologically raised access routes. As the body of the landfill 43 increases in height mats are laid out in a staggered arrangement on top of one another. The use of mats 9 as burnt aisle fire mats is represented in Fig. 52. The mats are laid out and set on fire in order to produce a counteracting fire. The spread of fire is thus effectively prevented during forest fires for example. The arrangement of mats 9 according to Fig. 54 serves the laying out of paddy fields for example. The use of mats in arid regions is represented in Fig. 55, where mats 9 are incorporated in the road or trail 34. If the roadway is covered by sand drifts a metal detector reacting to the metal parts woven into the mat can be used to locate the original route 34. Mats and interwoven bodies can be transported or put in place with the aid of carrier units such as gas-filled balloons, helicopters or airships. Transportation can be ei-



ther in horizontal or vertical position, as can be seen in
Fig. 56. The use of mats 9 and interwoven bodies (25) in
space is indicated in Fig. 57, where aerospace technology
(45) can be set up in a safety cage constructed from mats 9
5 or interwoven bodies 25.

The invention is not restricted to the exemplary embodi-
ments represented here. On the contrary, it is possible to
implement other embodiment variants by combination and
modification of the means and features explained without
10 abandoning the terms of reference of the invention.



List of reference codes

	1	Running tread	16	Counter shaft
	2	Side rings	17	Pole
	3	Tire	18	Depression
5	4	Guide	19	Reef
	5	Drive roller	20	Fish
	6	Shaft	21	Lock flooding basin
	7	Swelling	22	Buoy
	8	Cutting blade	23	Ice sheet
10	9	Mat	24	River
	10	Bank	25	Interwoven body
	11	Water	26	Waves
	12	Bed of body of water	27	Quay facilities
	13	Hollow body	28	Bridge pier
15	14	Waterproof sheeting	29	Sewage treatment tank
	15	Earth	30	Entry into tanks



- 31 Ship
- 32 Plants
- 33 Slope
- 34 Road
- 5 35 Pipe
- 36 Cable
- 37 Ground opening
- 38 Bunker
- 39 Crash barrier
- 10 40 Load
- 41 Tree
- 42 Silage heap
- 43 Body of landfill
- 44 Paddy fields
- 15 45 Aerospace technology



THE CLAIMS DEFINING THE INVENTION ARE AS FOLLOWS:

1. A method for processing tires and the manufacture of products composed of tire material wherein the tires are dismembered by a sequence of cuts, said method characterized in that the two side walls are separated from the running tread and the rings arising are combined together to new products by means of a weaving process.
2. The method according to claim 1, characterized in that the products are interwoven mesh surface structures or bodies.
3. The method according to claim 2, characterized in that the interwoven mesh surface structures are mats or aligned units and the bodies are three-dimensional blocks or hollow bodies.
4. The method according to any one of claims 1 to 3, characterized in that narrower rings of equal diameter are generated from further cuts along the circumference of the ring produced from the running tread.
5. The method according to any one of claims 1 to 4, characterized in that narrower rings of varying diameter are generated from further cuts along the circumference of the ring produced from the side walls.
6. The method according to at least one of the claims 1 to 5, characterized in that



production of the individual rings is carried out by means of permanently installed cutting facilities or by means of mobile cutting facilities.

- 5 7. The method according to claim 6,
characterized in that
the tires are cut with a single cut along the middle of the
running tread in such a way that two U-shaped tire parts
result which can be stacked inside each other for the
10 purpose of their transportation to the permanent cutting
facilities.



- 15 8. The method according to any one of claims 1 to 7,
characterized in that
the rubber is kept under tension during the process of
cutting.



- 20 9. A block, hollow body, mat or aligned units consisting of
interwoven rings from cut up tires.
- 25 10. A method for producing the products block, hollow body, mat
or aligned units of claim 9, said method
characterized in that
for the purpose of interweaving the rings, the initial ring
is pressed together in such a way that approximately equal
size loops are formed to the left and right and that a
further ring is fed through both of these loops such that
the ring fed through forms two further loops.

- 30 11. The method according to claim 10,
characterized in that
the external ring and/or end ring is prevented from opening
by means of fixation.



12. A method for producing the products block, hollow body, mat or aligned units of claim 9, said method characterized in that the interweaving is carried out manually or by a machine.

5

13. A method according to claim 12, characterized in that the interweaving process for blocks mats or aligned units is carried out at the place of deployment.

10

14. The use of mats, hollow bodies, blocks or aligned units produced by interweaving rings composed of tire material for purposes selected from any one or more of the following:

the construction of dam reinforcement;

bank protection measures;

treatment of the beds of bodies of water;

artificial dams;

protective measures on reefs and coral banks;

fish breeding measures;

recovery measures in sluice locks or pools;

protective measures against breaking through ice sheets;

wave protection measures;

collision protective measures close to building structures;

filtration or cleaning functions;

earth consolidation;

plant protective measures;

avalanche or falling rock protective measures;

substrate consolidation in foundations, roads and open spaces;

cable or pipe shafts;

explosion protective elements;

shelters;

traffic guidance elements;

tree protective measures;

drainage functions;

25

30



demarcations;
load redistribution elements;
silage covers;
landfill demarcations;
5 fire mats;
roadway marking; and/or
agricultural areas.

15. A method for processing tires and the manufacture of
10 products composed of tire material substantially as
hereinbefore described with reference to any one or more of
the accompanying drawings.



16. A block, hollow body, mat or aligned units substantially as
15 hereinbefore described with reference to any one or more of
the accompanying drawings.



17. The use of mats, hollow bodies, blocks or aligned units for
20 the purposes as hereinbefore described with reference to
Figures 4 to 57 of the accompanying drawings.

DATED THIS FOURTH DAY OF APRIL 2002.

Burkhard Schmeling

BY

25 PIZZEYS PATENT AND TRADE MARK ATTORNEYS



1/75

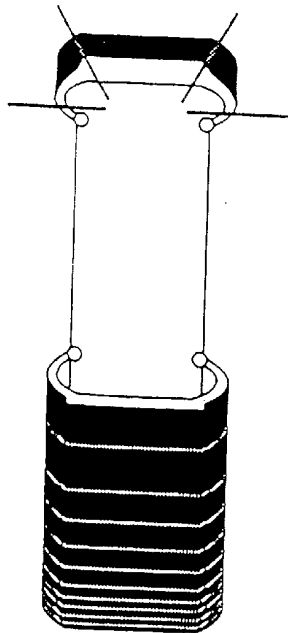
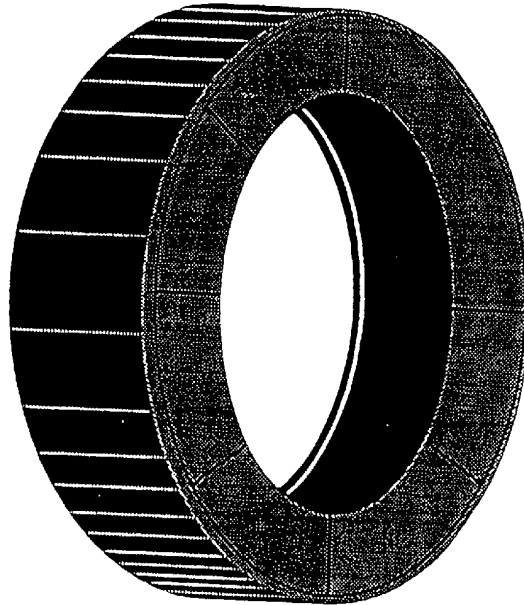

Fig. 1

ERSATZBLATT (REGEL 26)

2/75

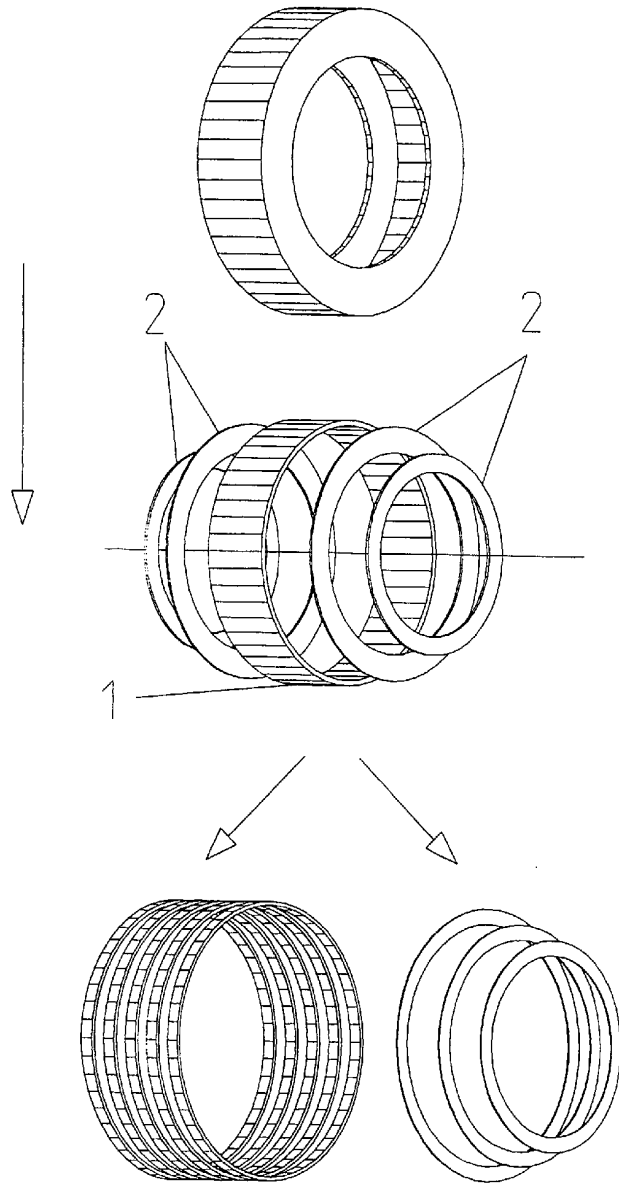

Fig. 2

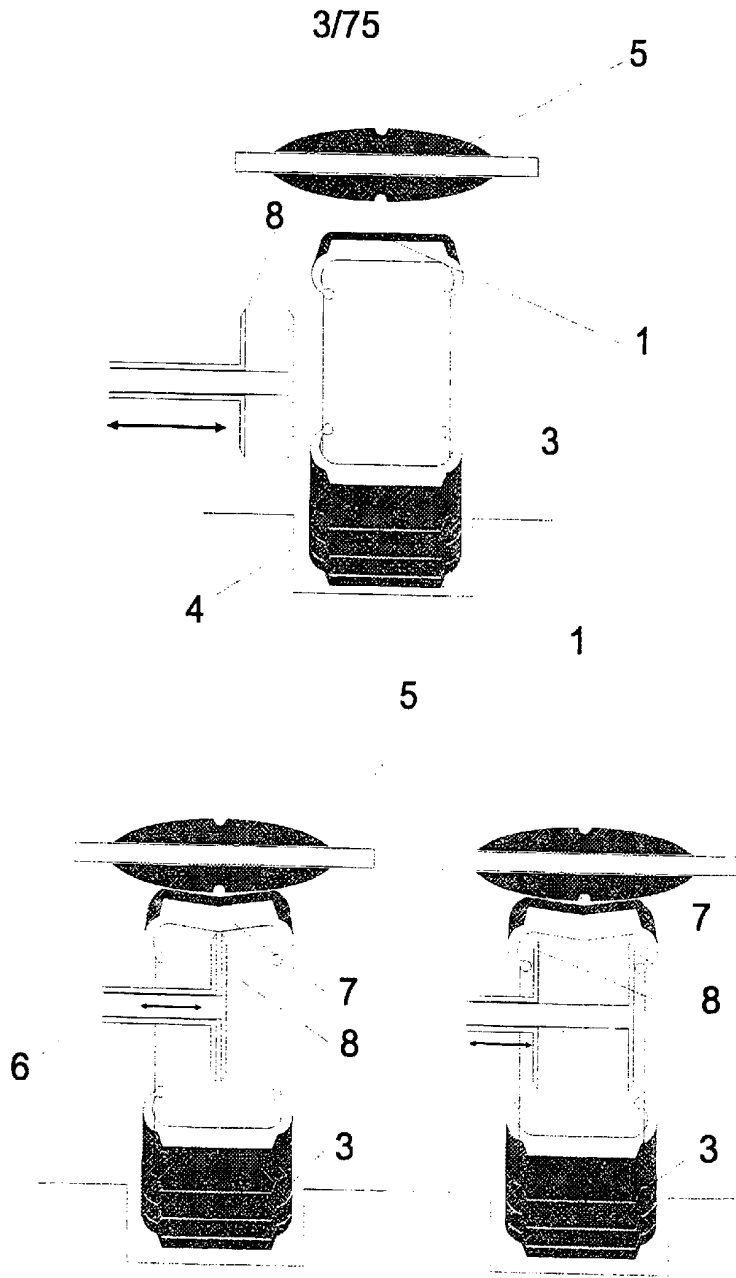

Fig. 2A

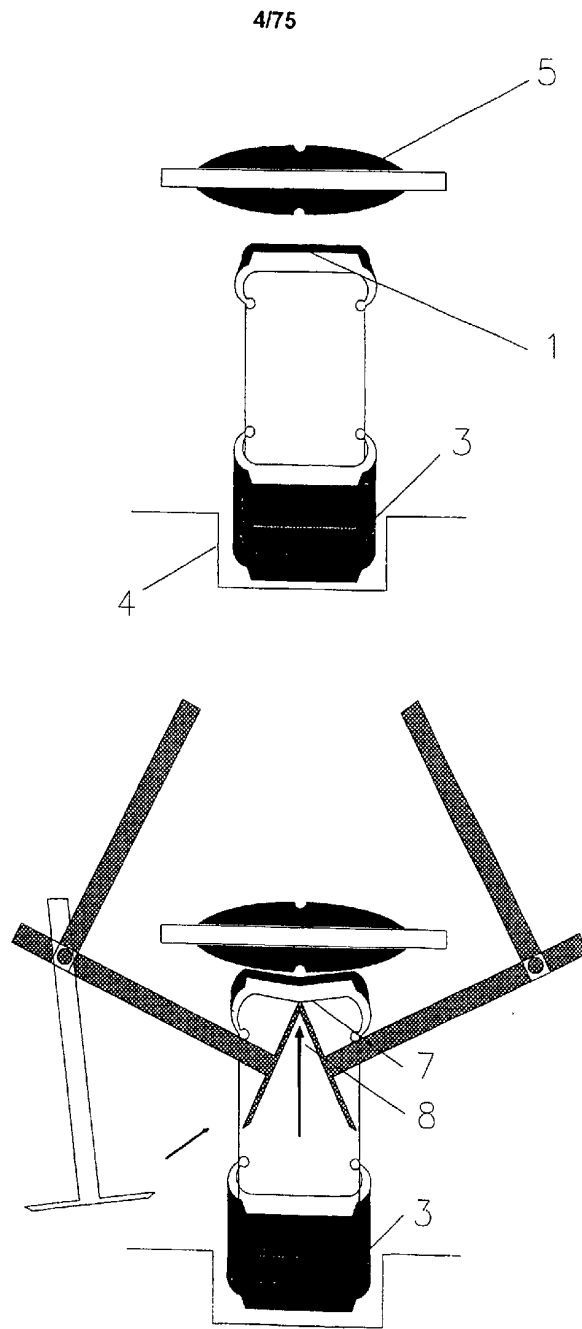

Fig. 2B

ERSATZBLATT (REGEL 26)

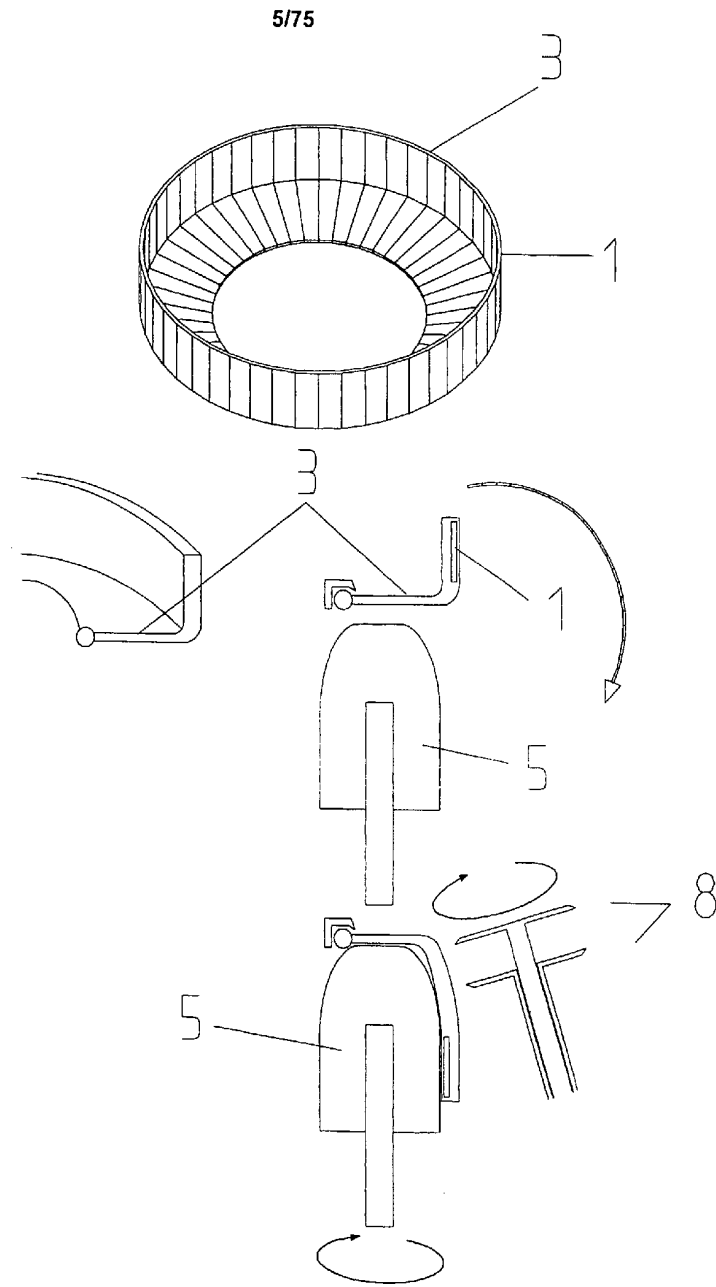

Fig. 2C

ERSATZBLATT (REGEL 26)

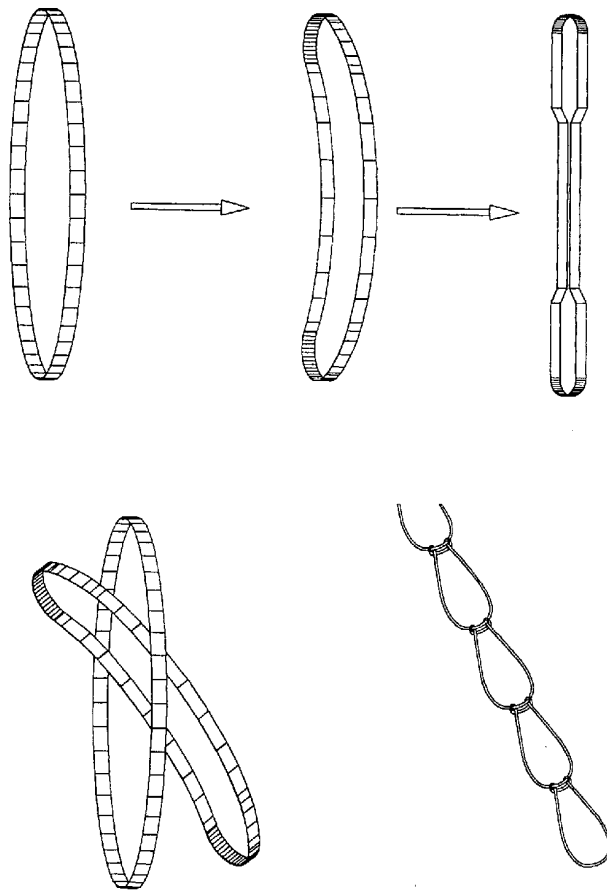

Fig. 3A

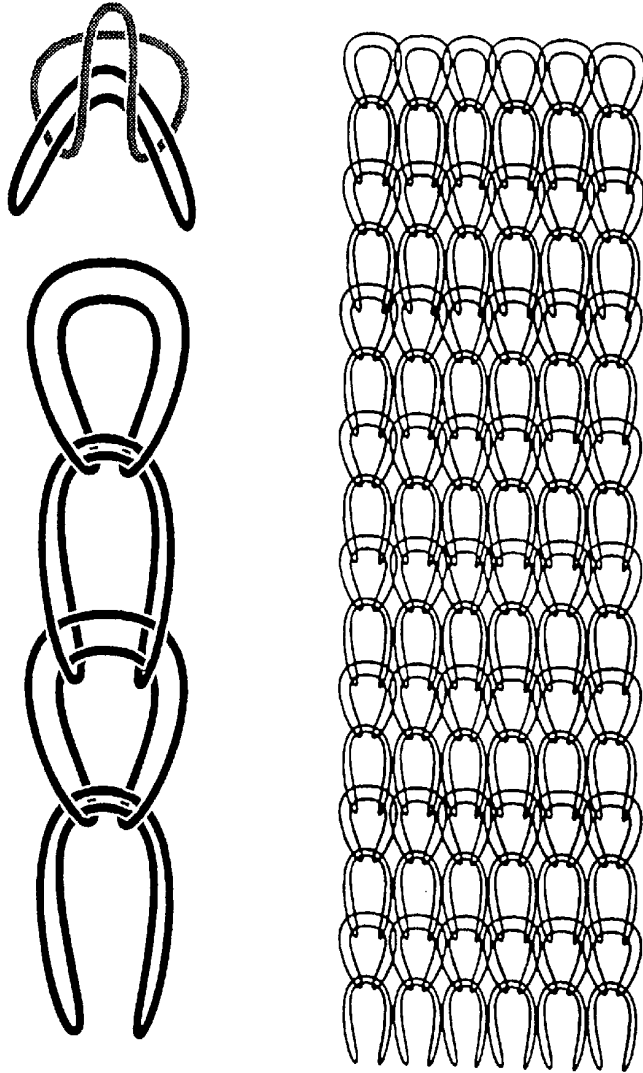

Fig. 3B

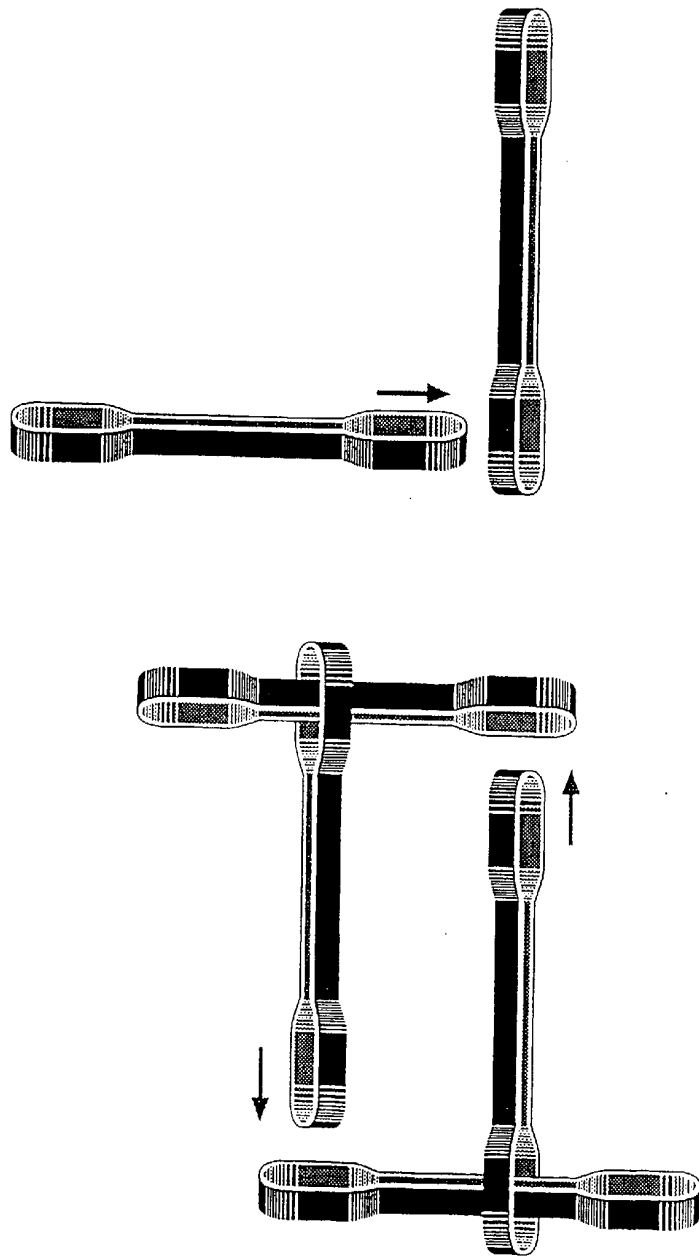

Fig. 3C

9/75

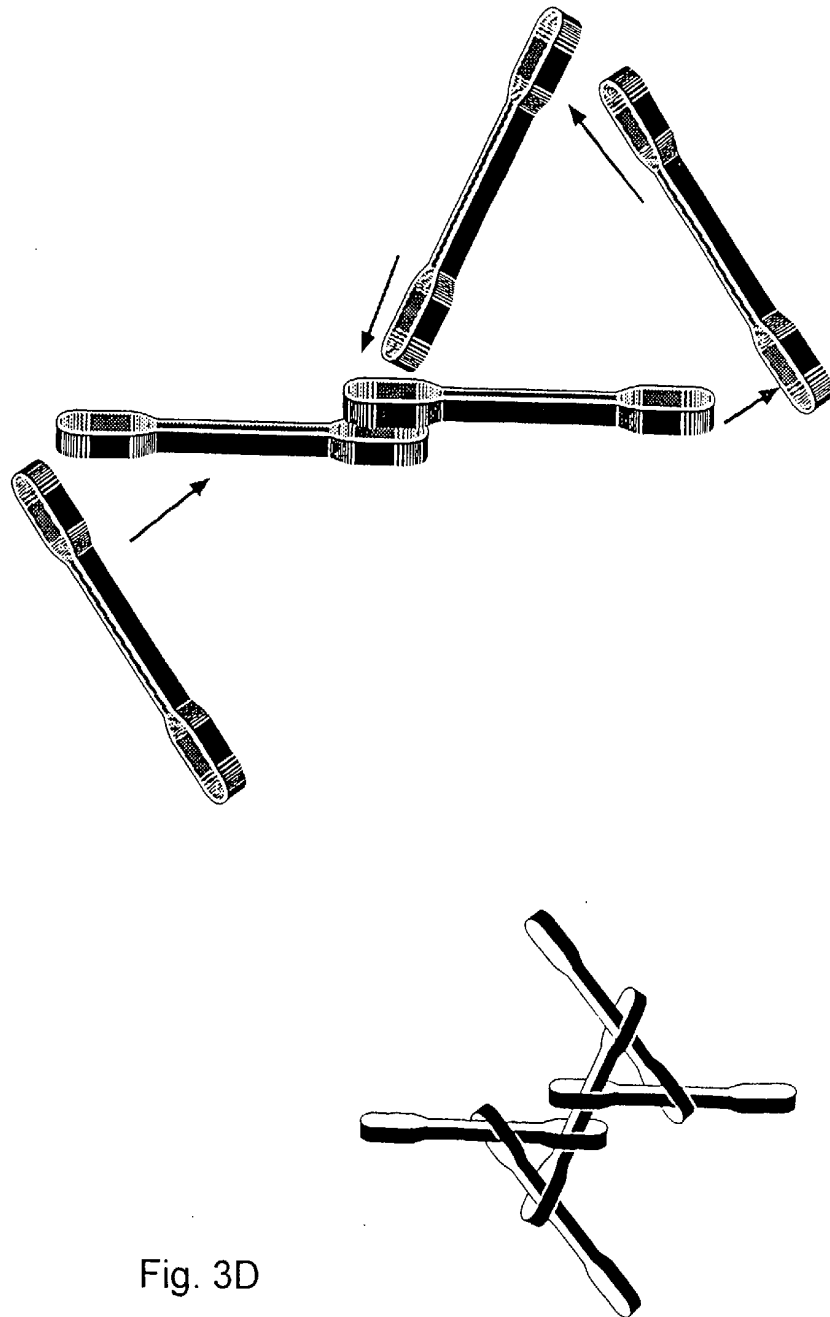

Fig. 3D

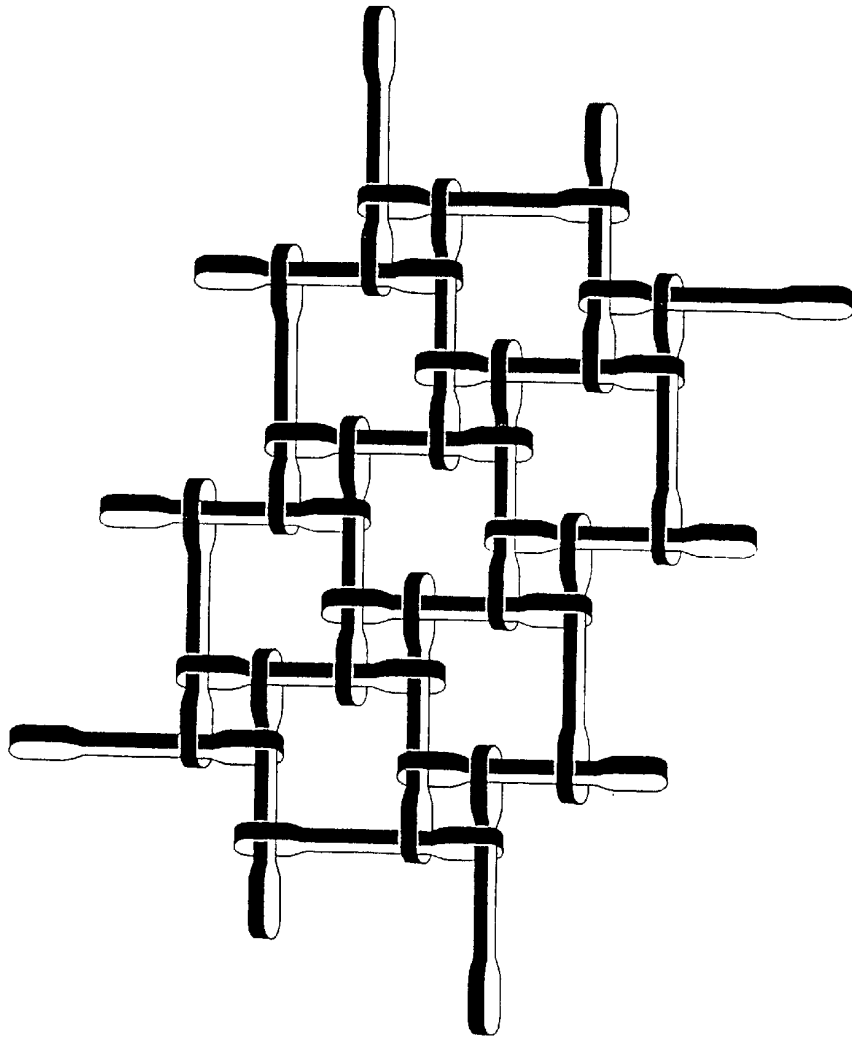

Fig. 3E

11/75

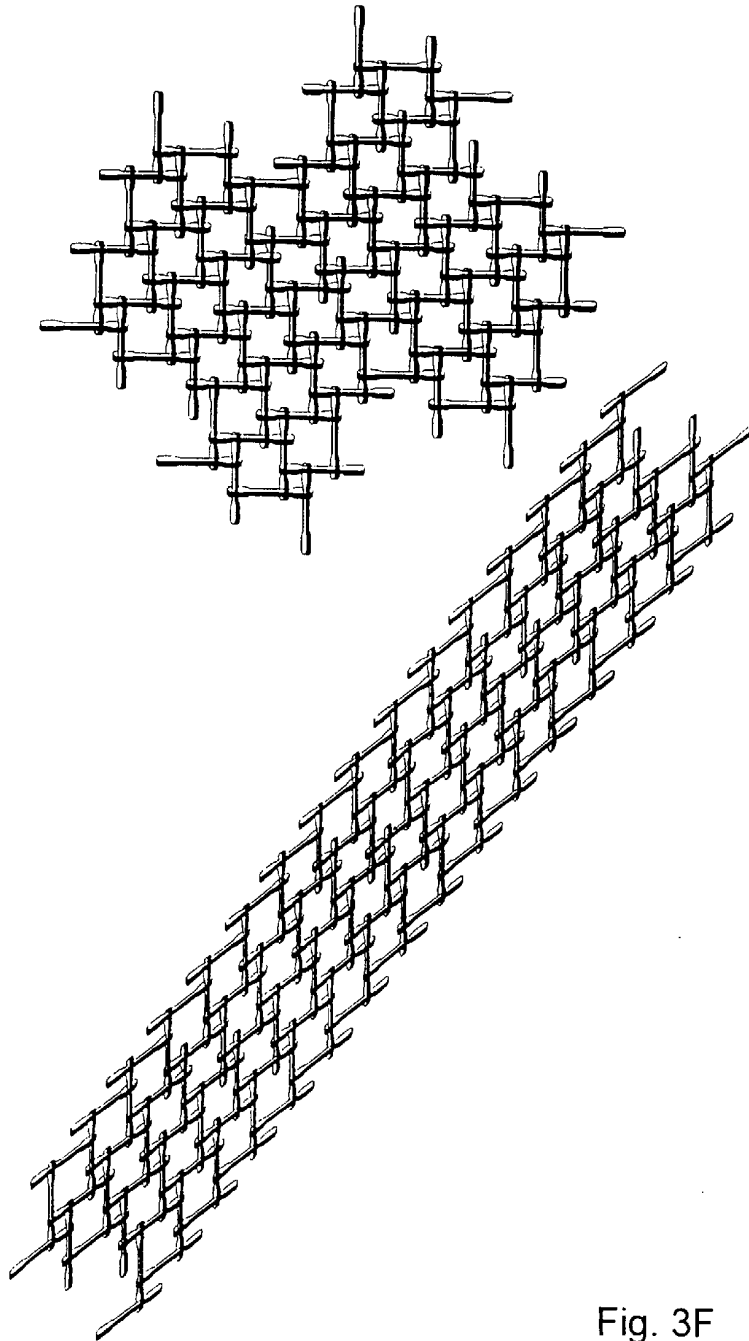

Fig. 3F

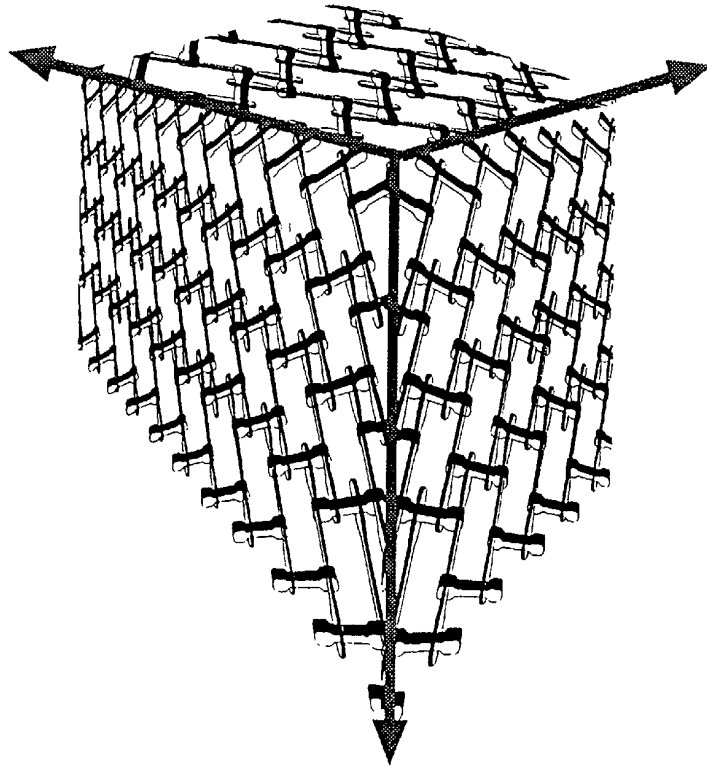

Fig. 3G

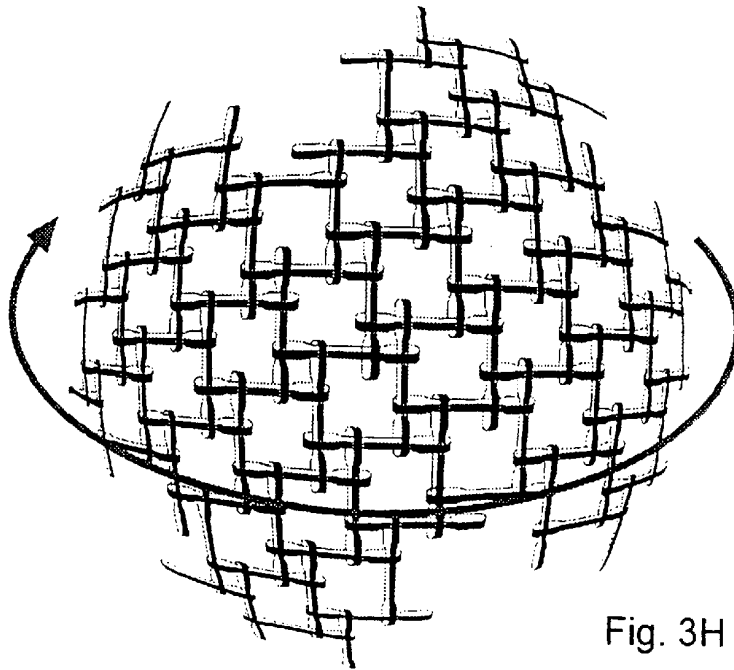
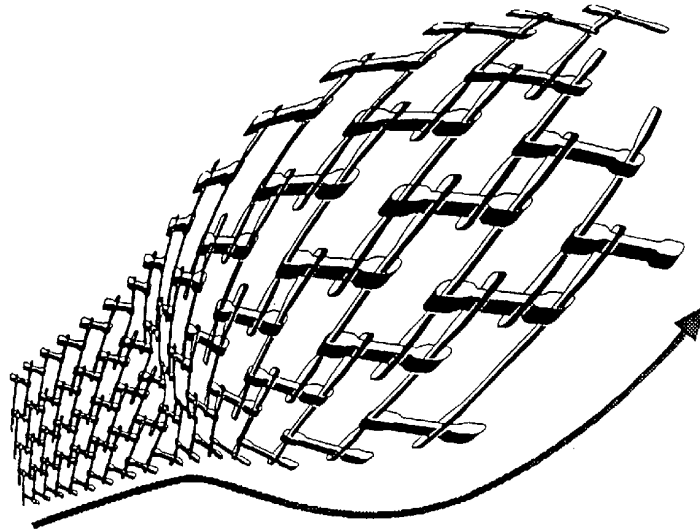

Fig. 3H

ERSATZBLATT (REGEL 26)

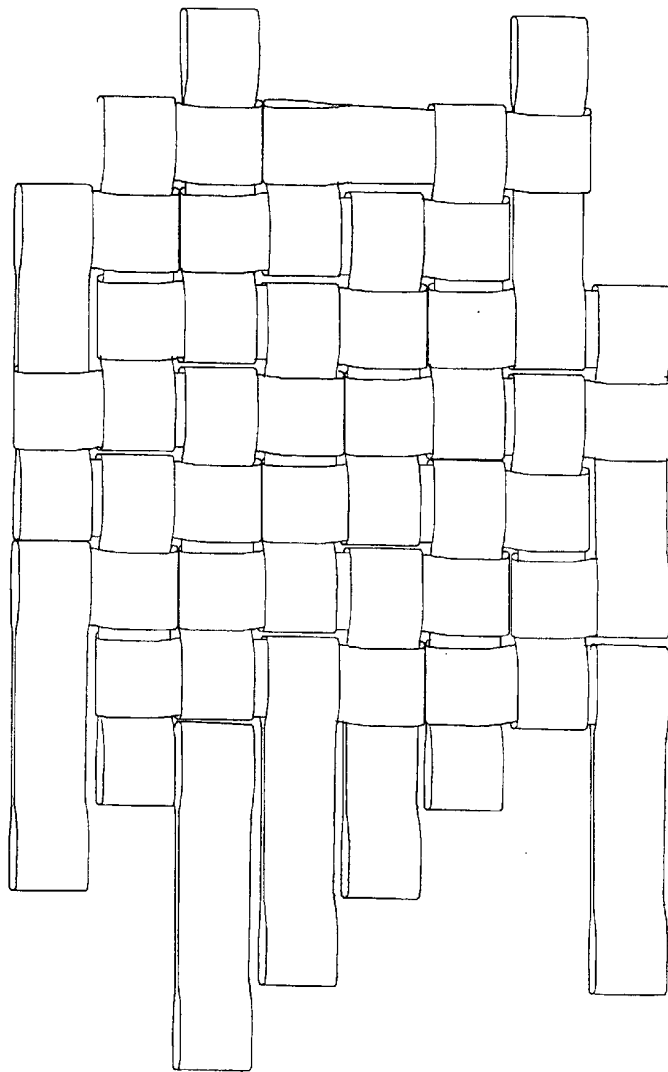

Fig. 3K

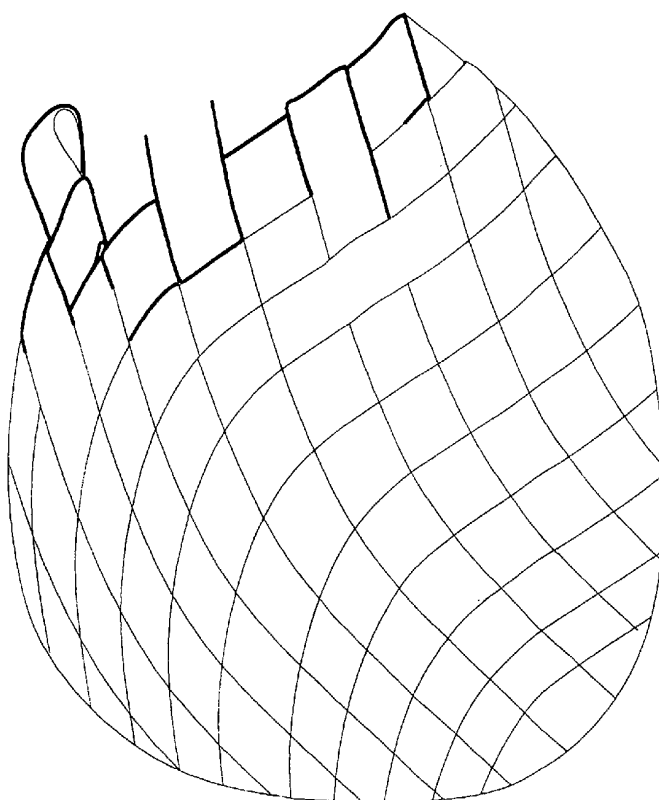

Fig. 3L

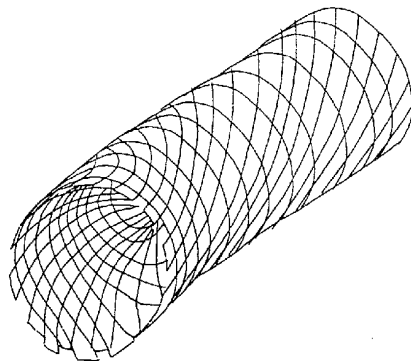

Fig. 3M

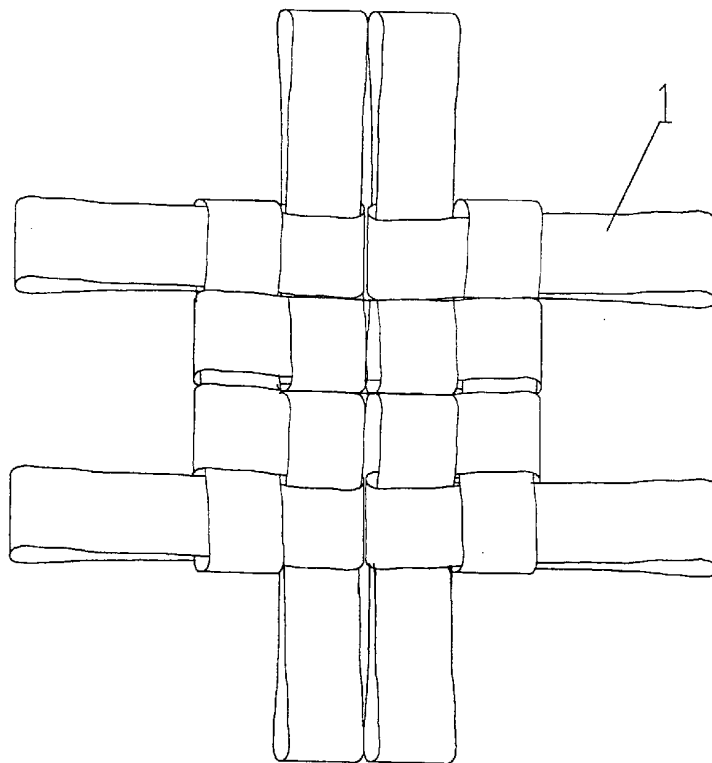

Fig. 3N

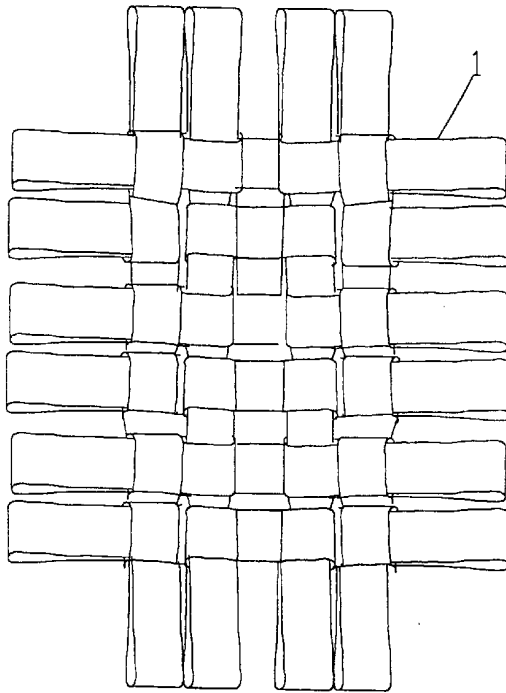

Fig. 3 O

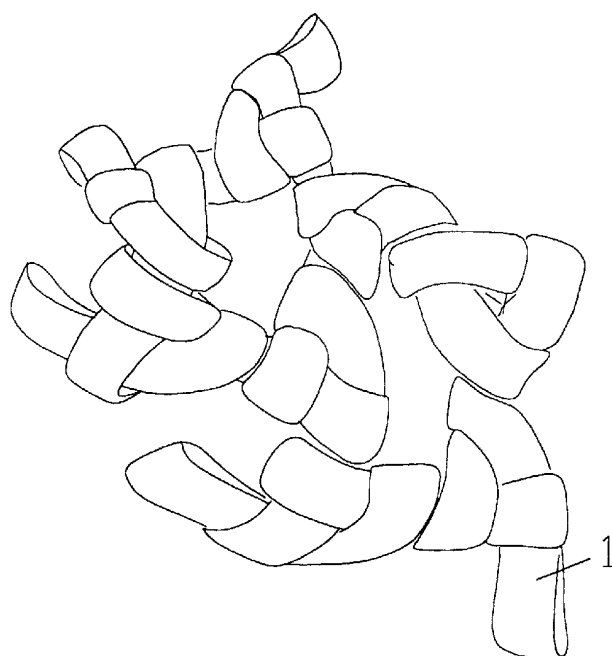

Fig. 3P

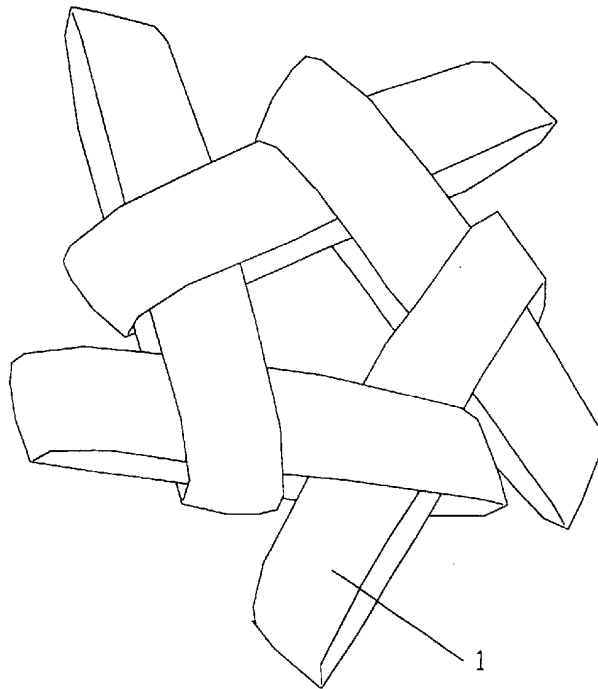

Fig. 3Q

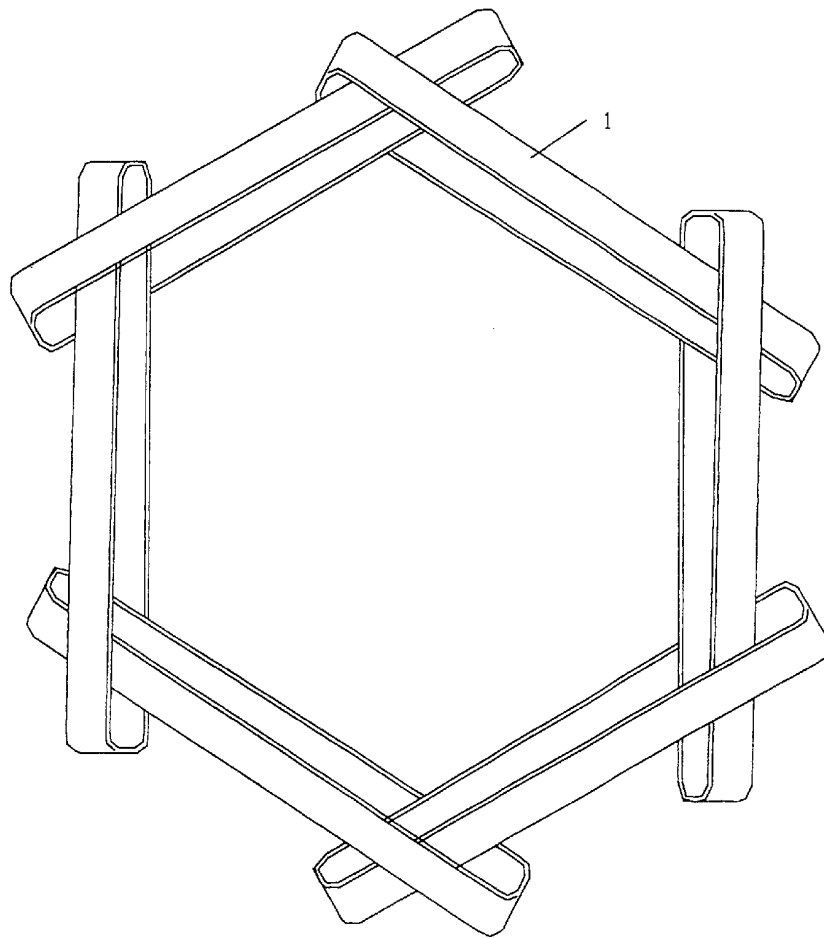

Fig. 3R

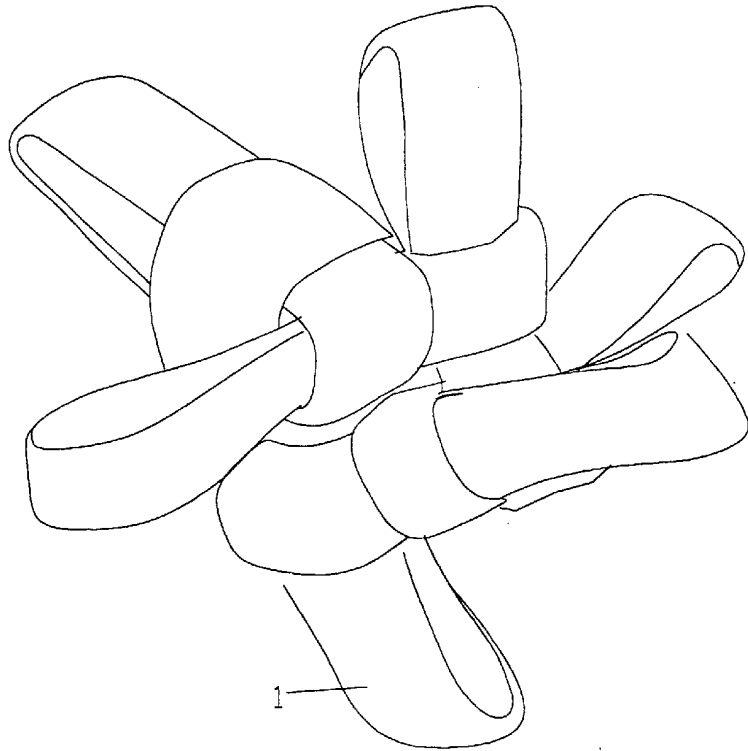

Fig. 3S

23/75

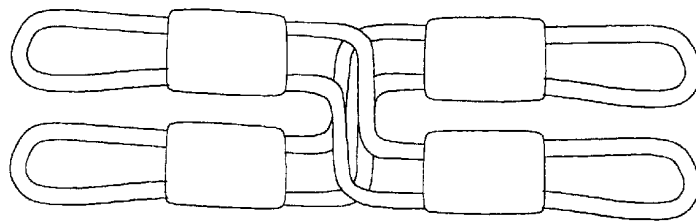

Fig. 3 T

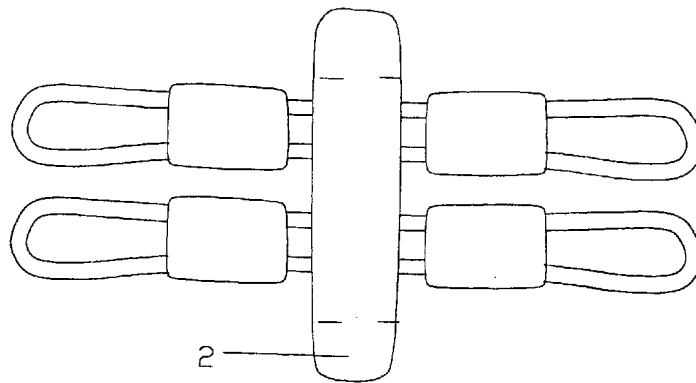

Fig. 3 U

23a / 75

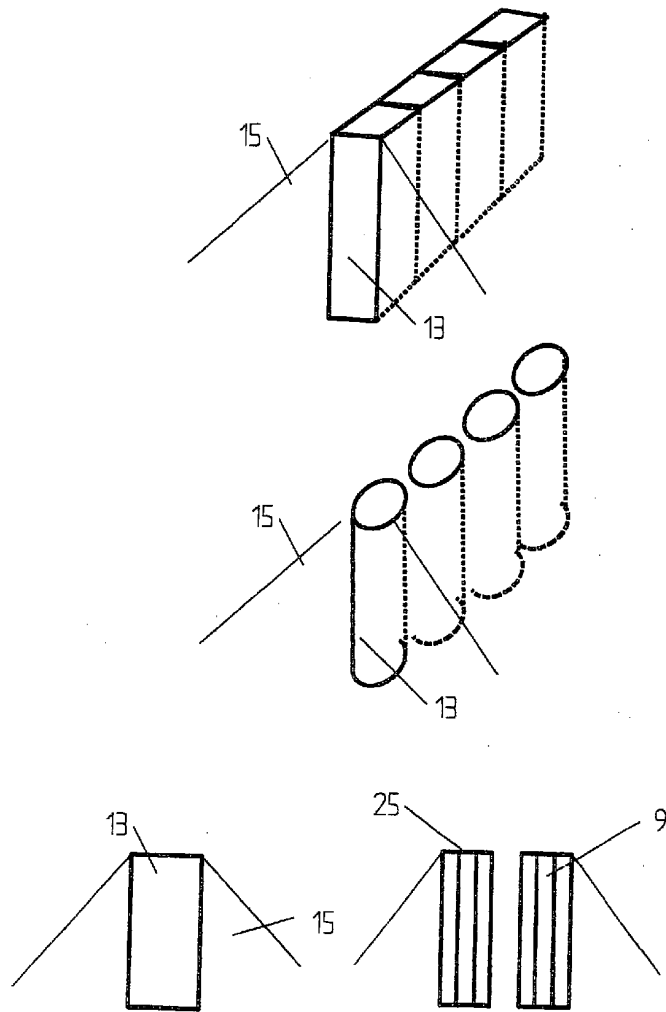

Fig. 4

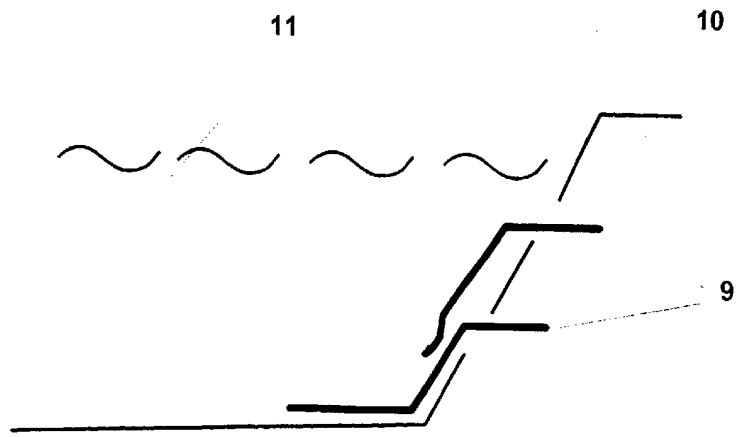

Fig. 5

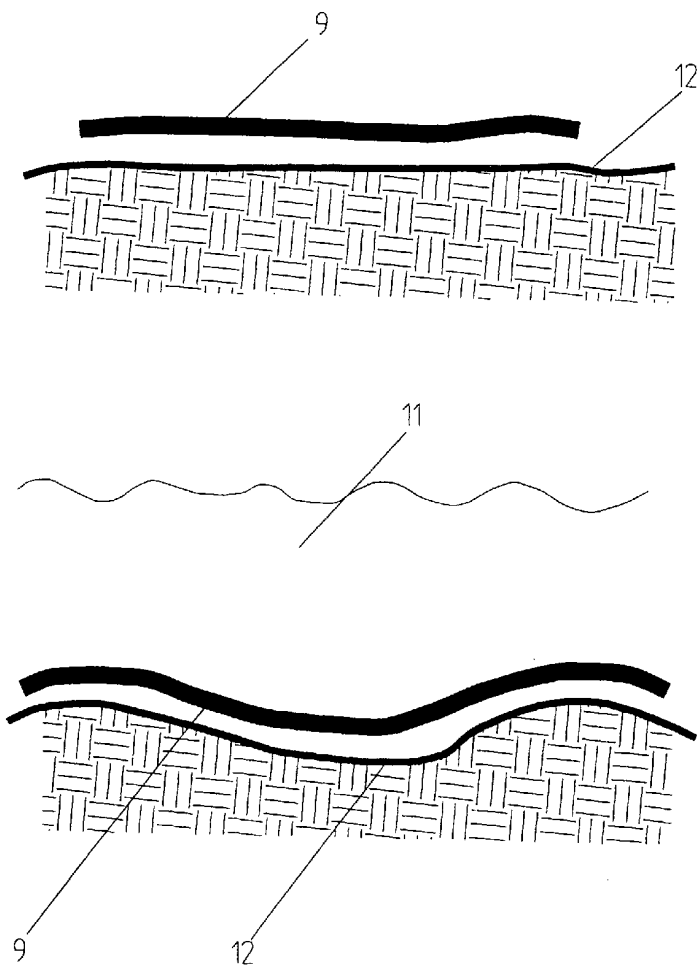

Fig. 6

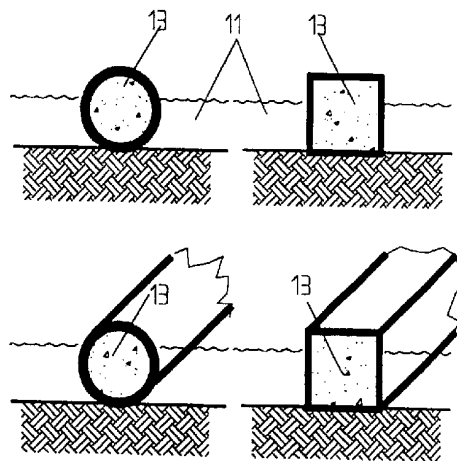

Fig. 7

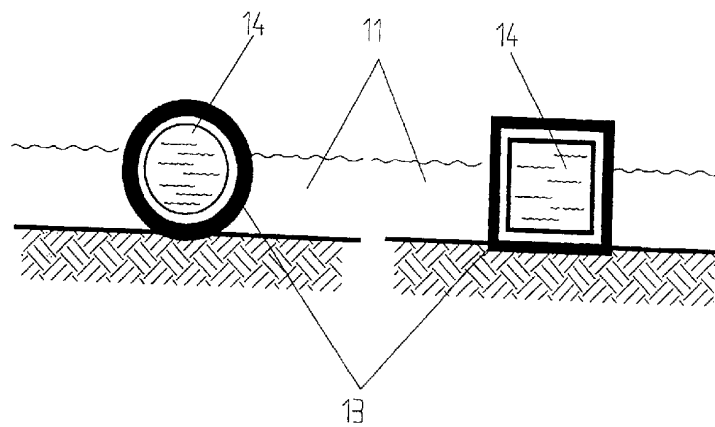

Fig. 8

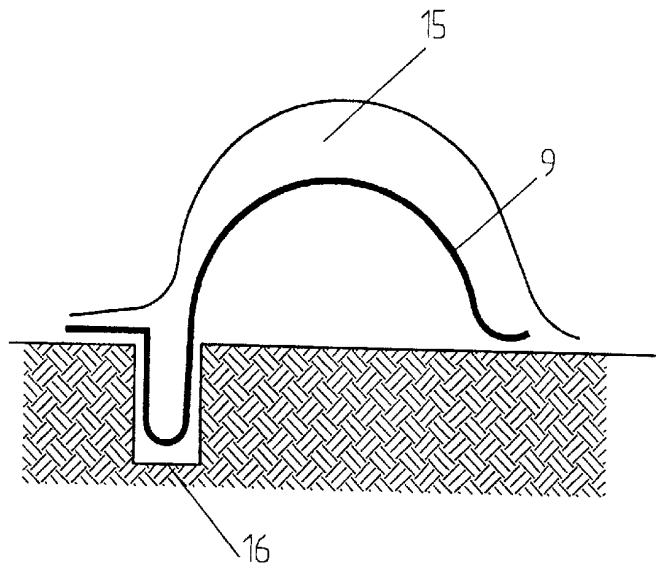
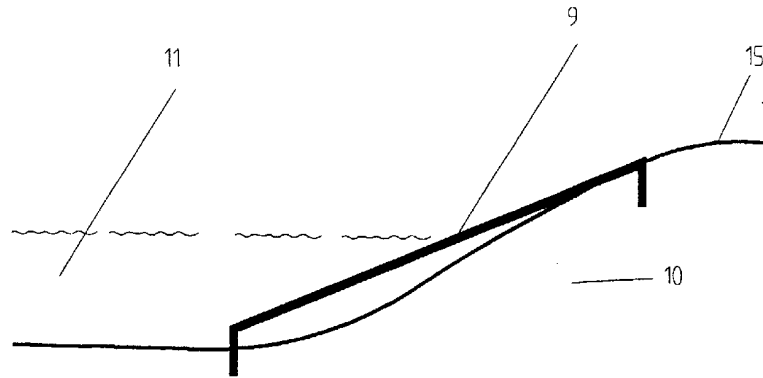

Fig. 9



30/75

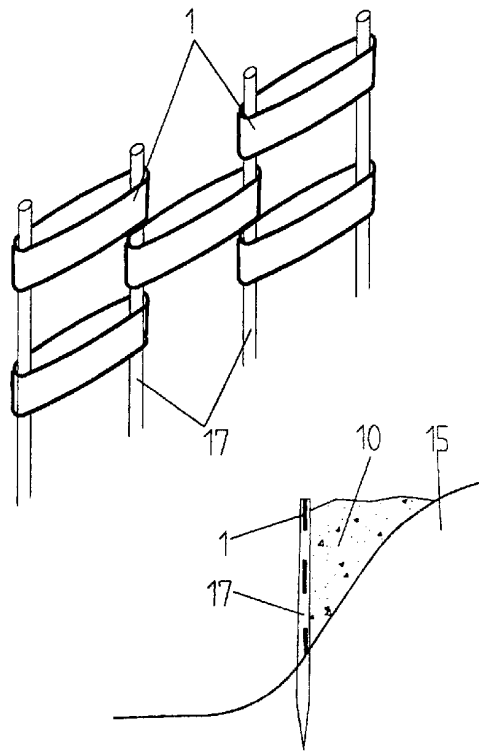

Fig. 11

31/75

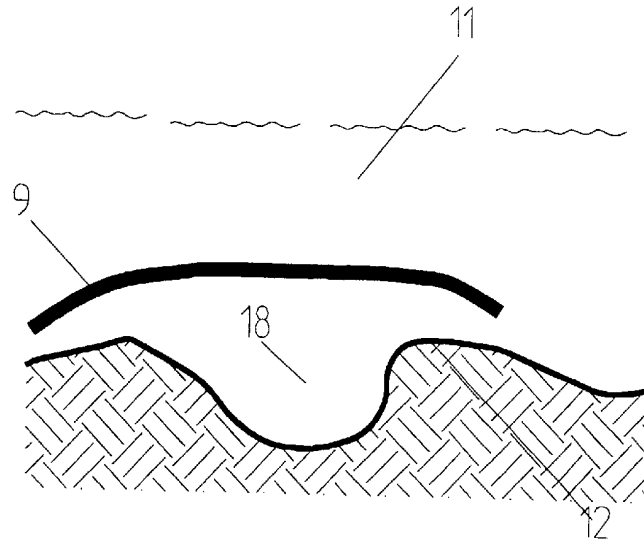

Fig. 12

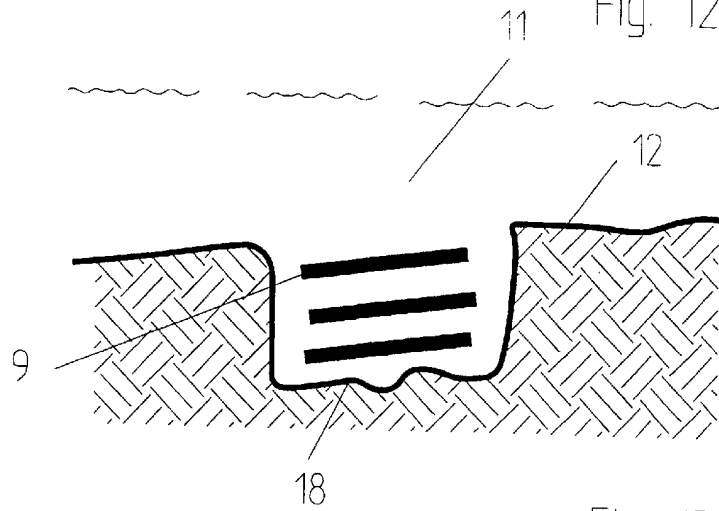

Fig. 13

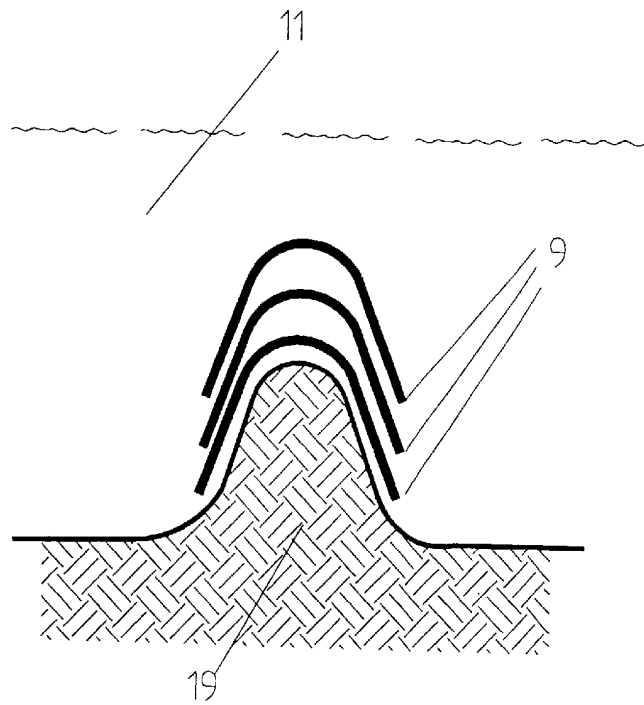

Fig. 14

33/75

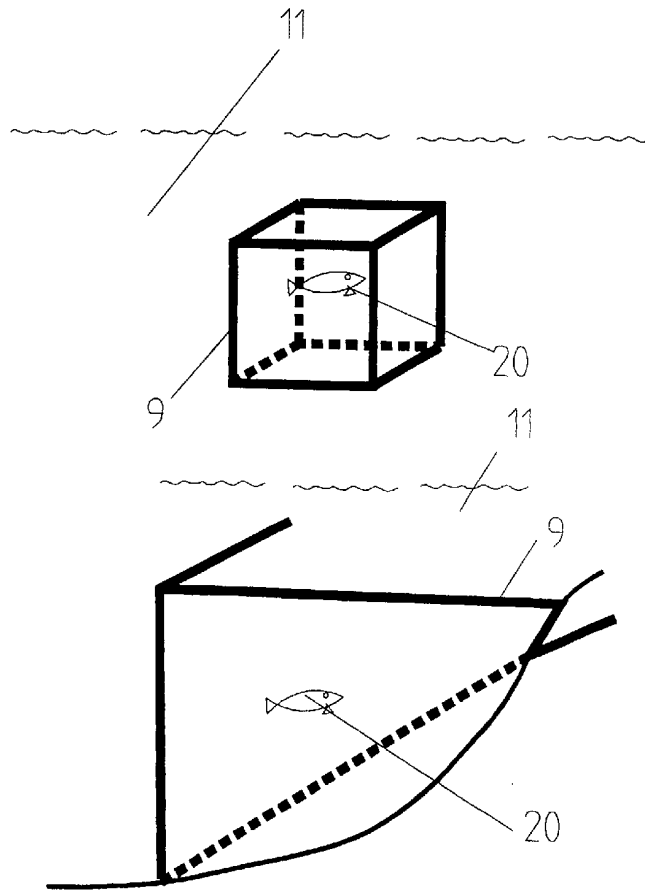

Fig. 15

34/75

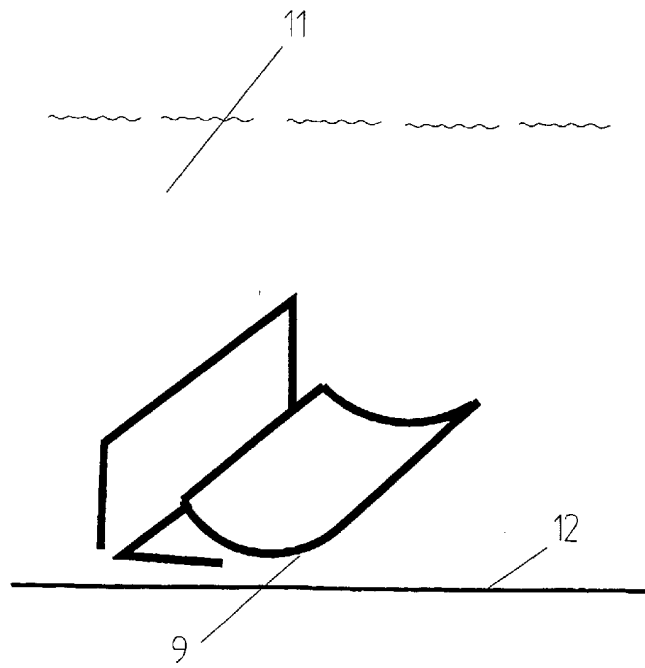

Fig. 16

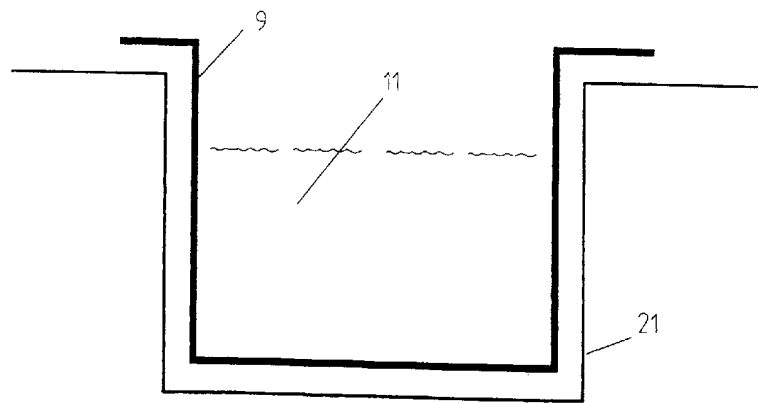

Fig. 17

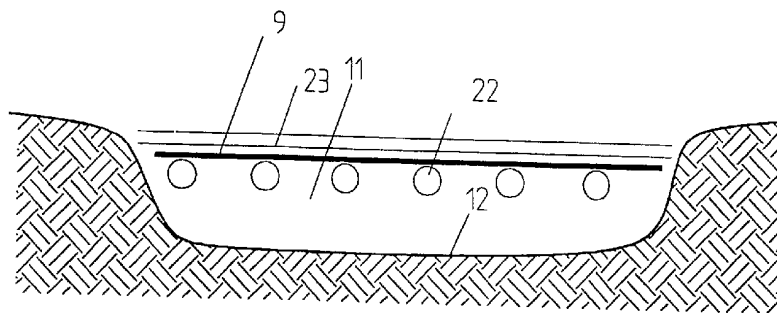

Fig. 18

37/75

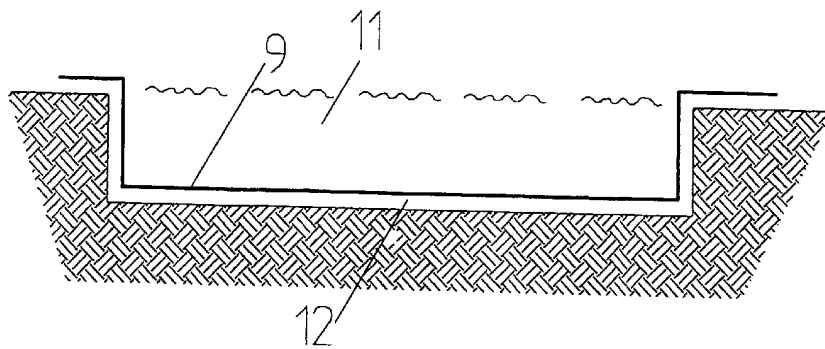

Fig. 19

38/75

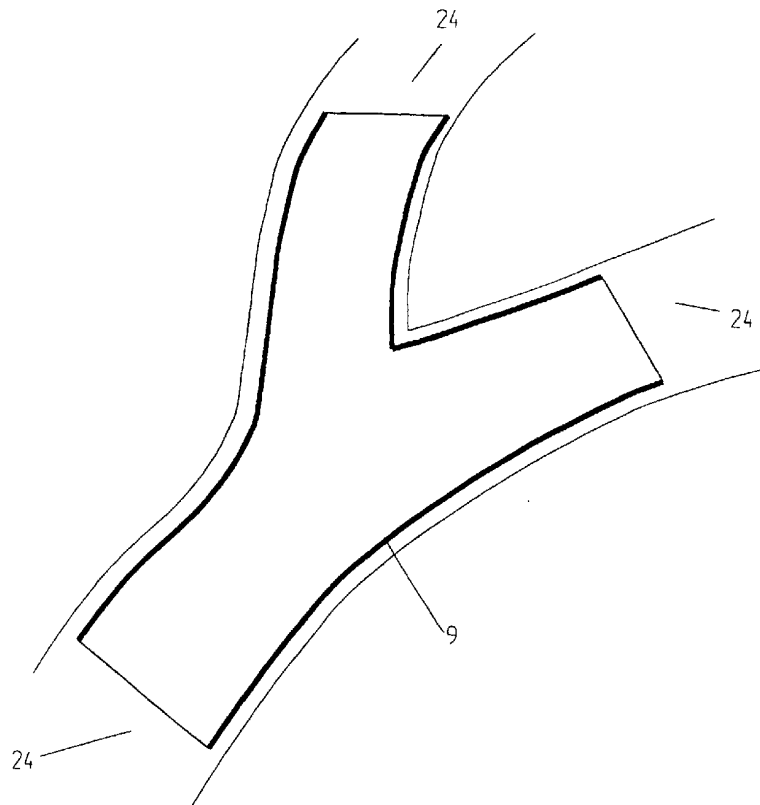

Fig. 20

ERSATZBLATT (REGEL 26)

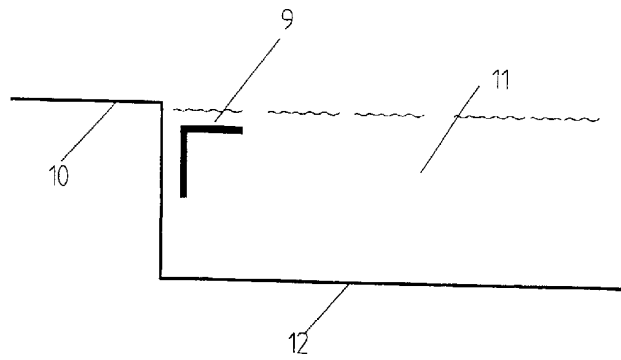

Fig. 21

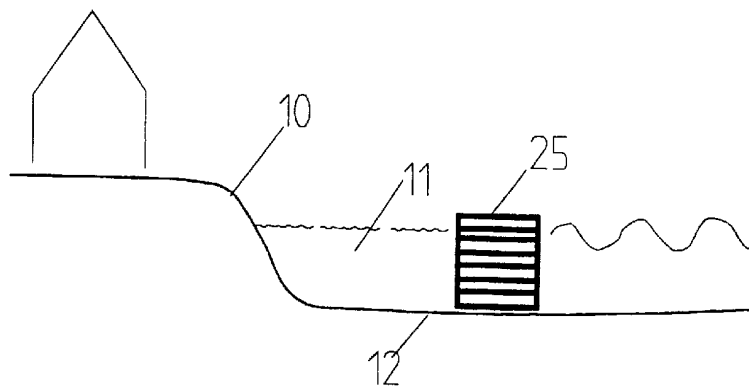

Fig. 22

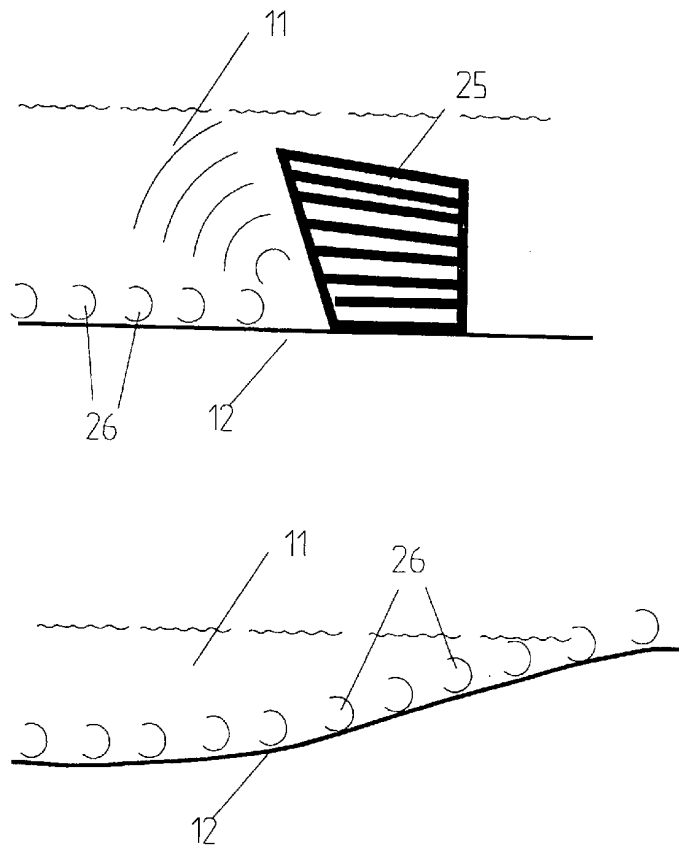

Fig. 23

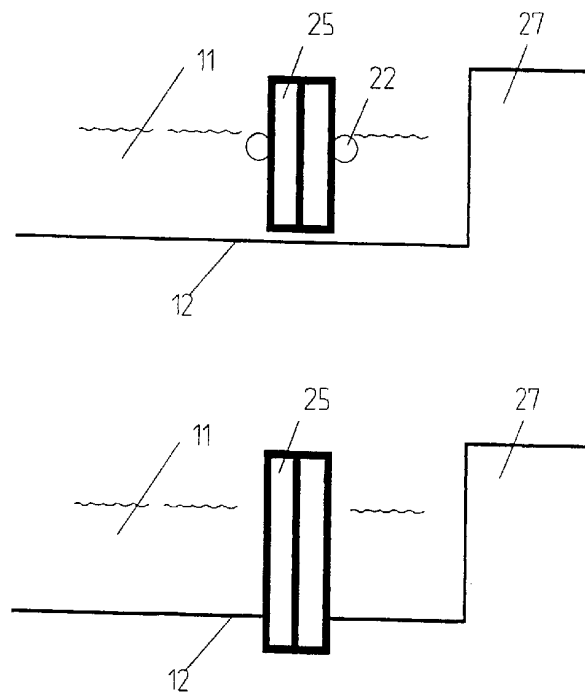

Fig. 24

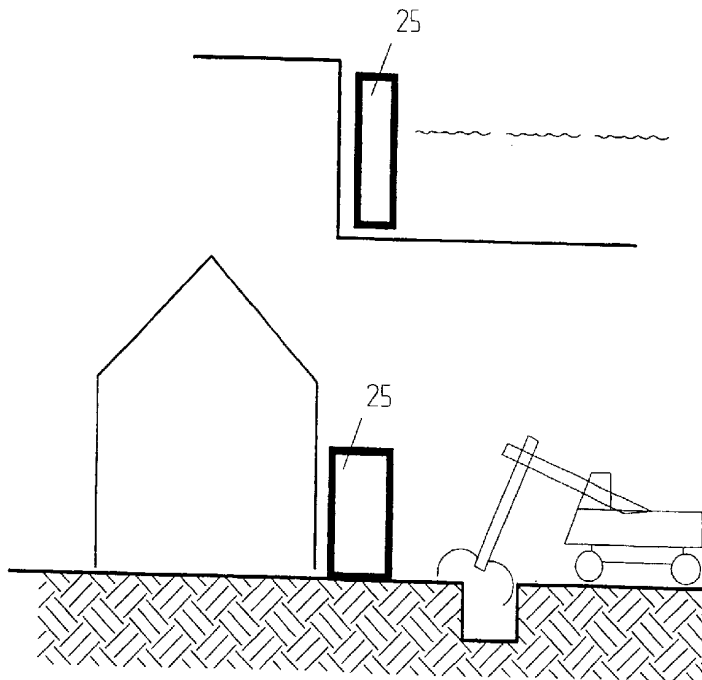

Fig. 25

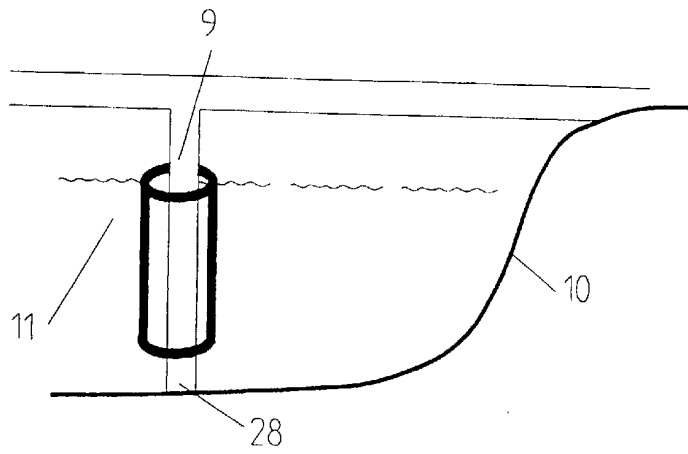

Fig. 26

45/75

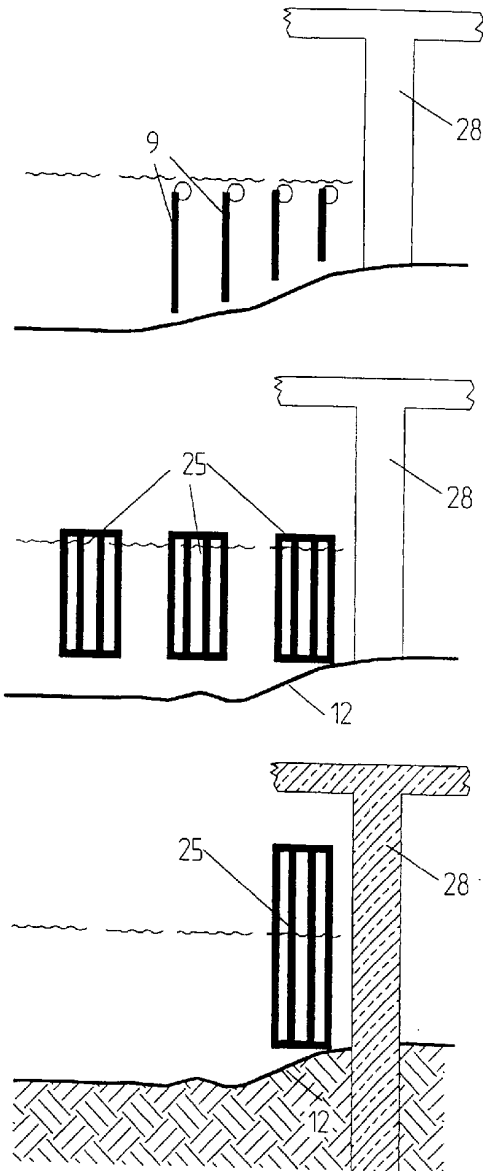

Fig. 27

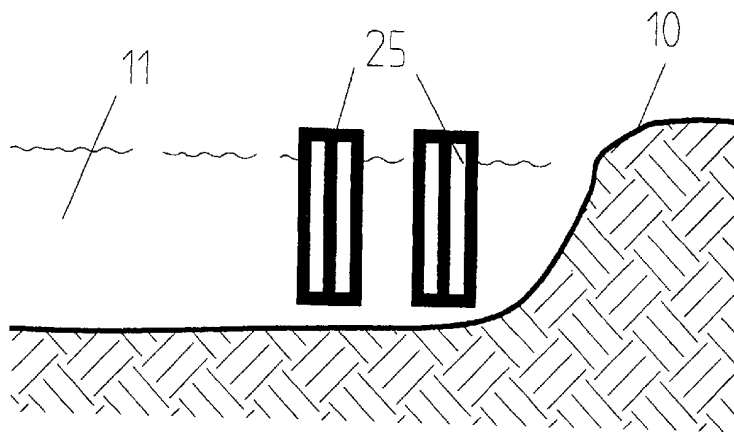

Fig. 28

47/75

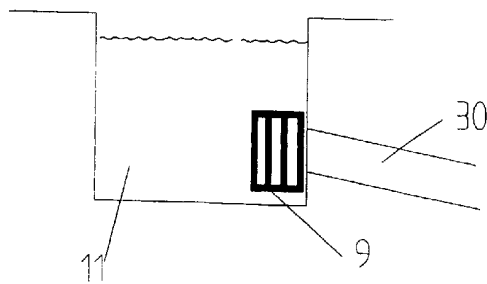
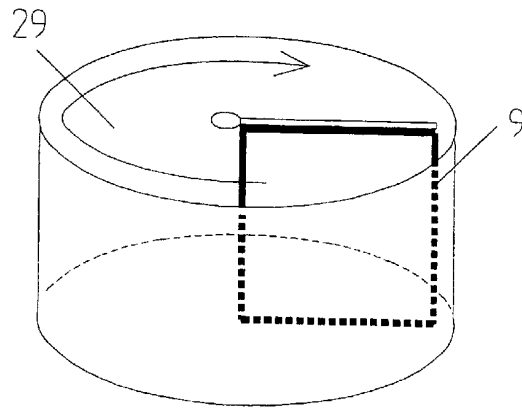
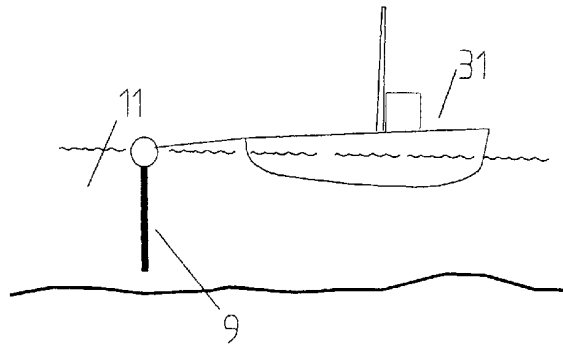

Fig. 29

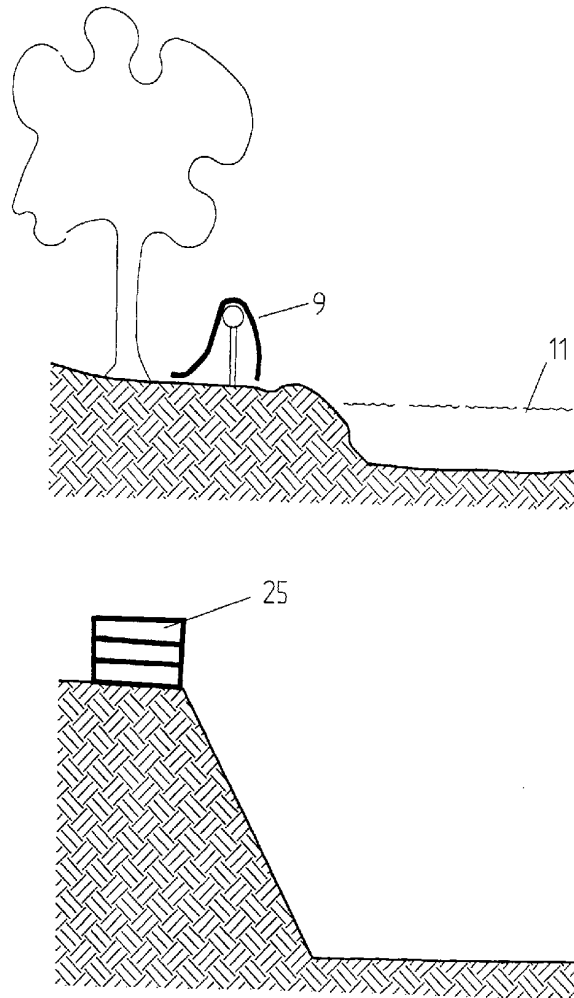

Fig. 30

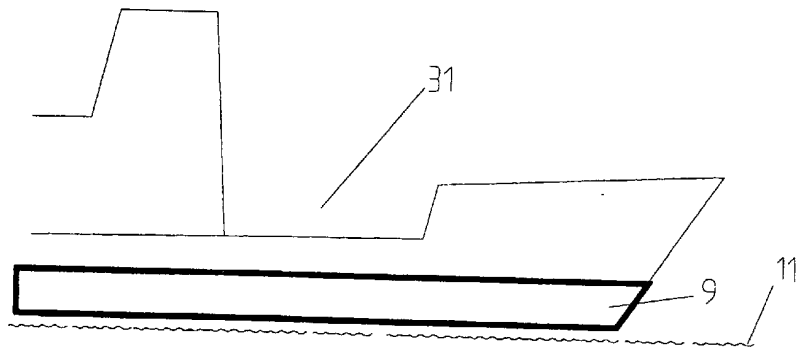

Fig. 31

50/75

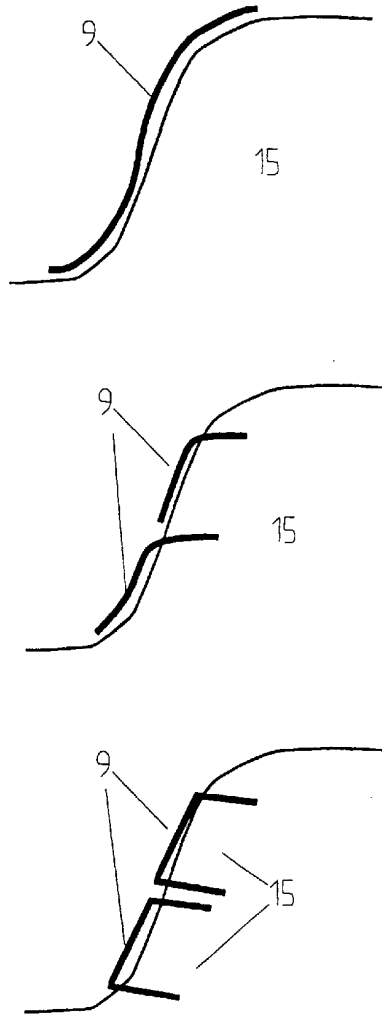

Fig. 32

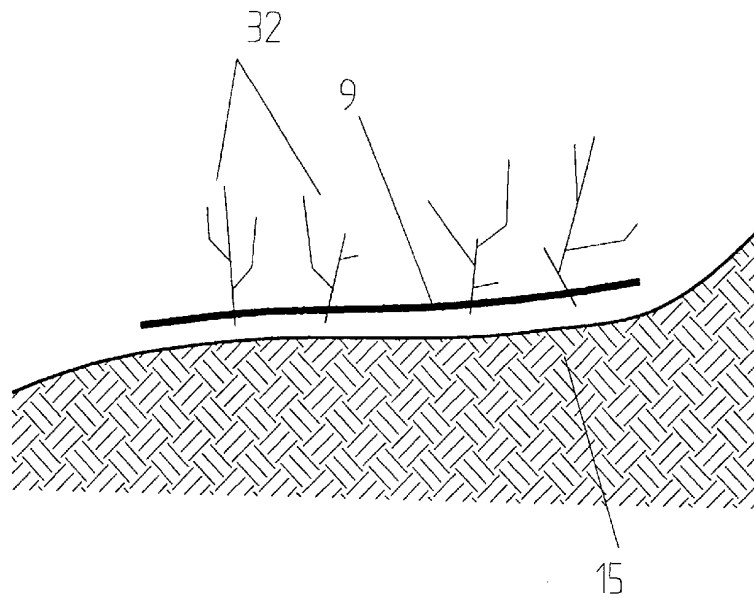

Fig. 33

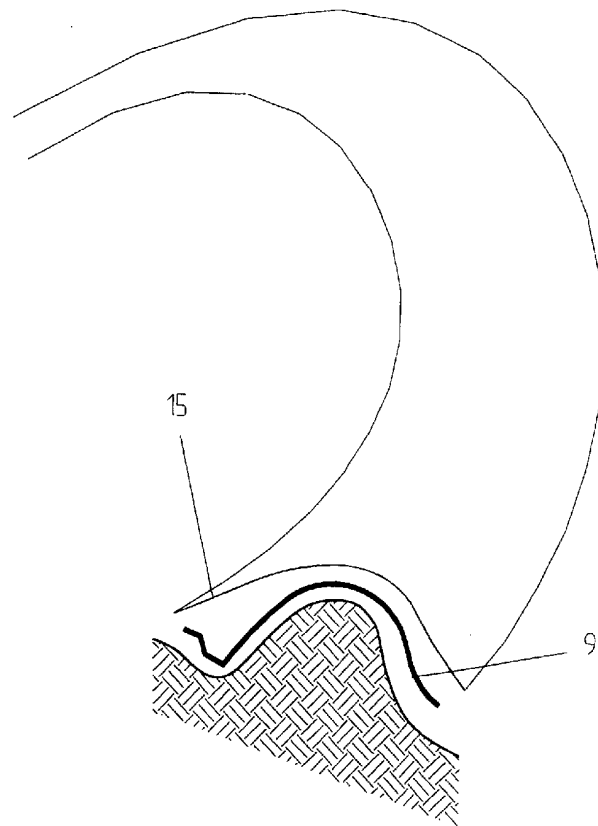

Fig. 34

53/75

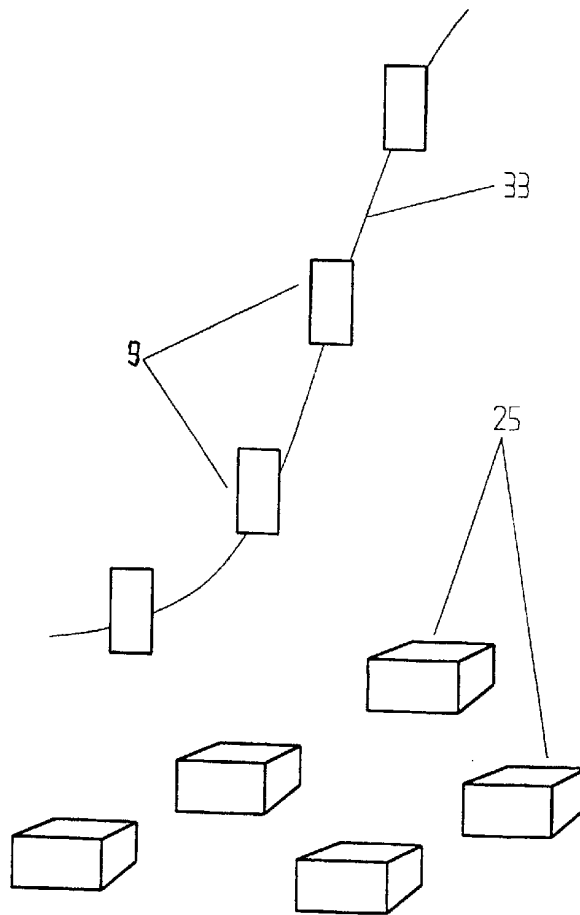

Fig. 35

54/75

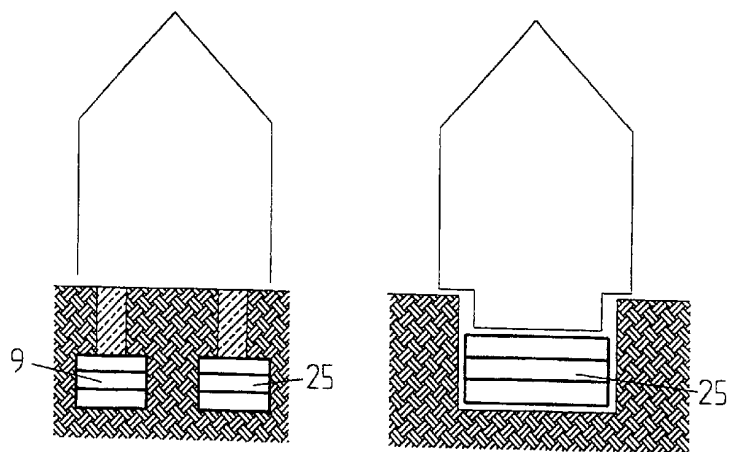

Fig. 36

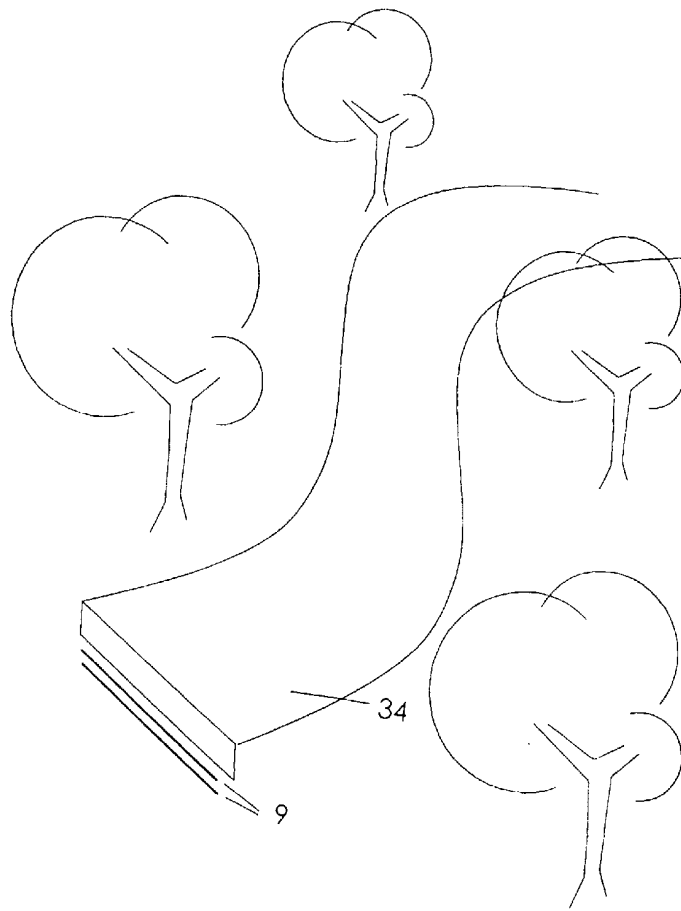

Fig. 37

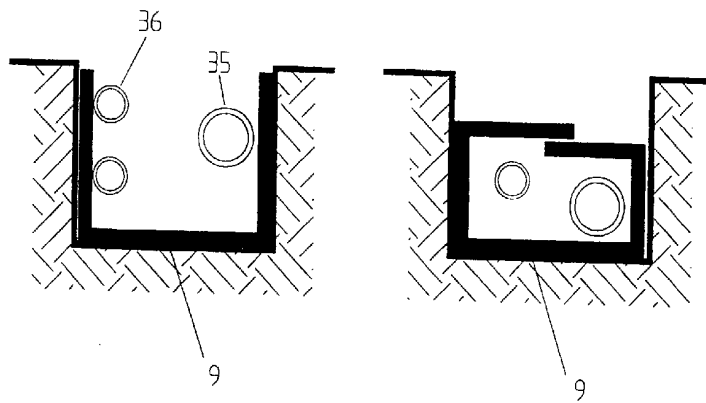

Fig. 38

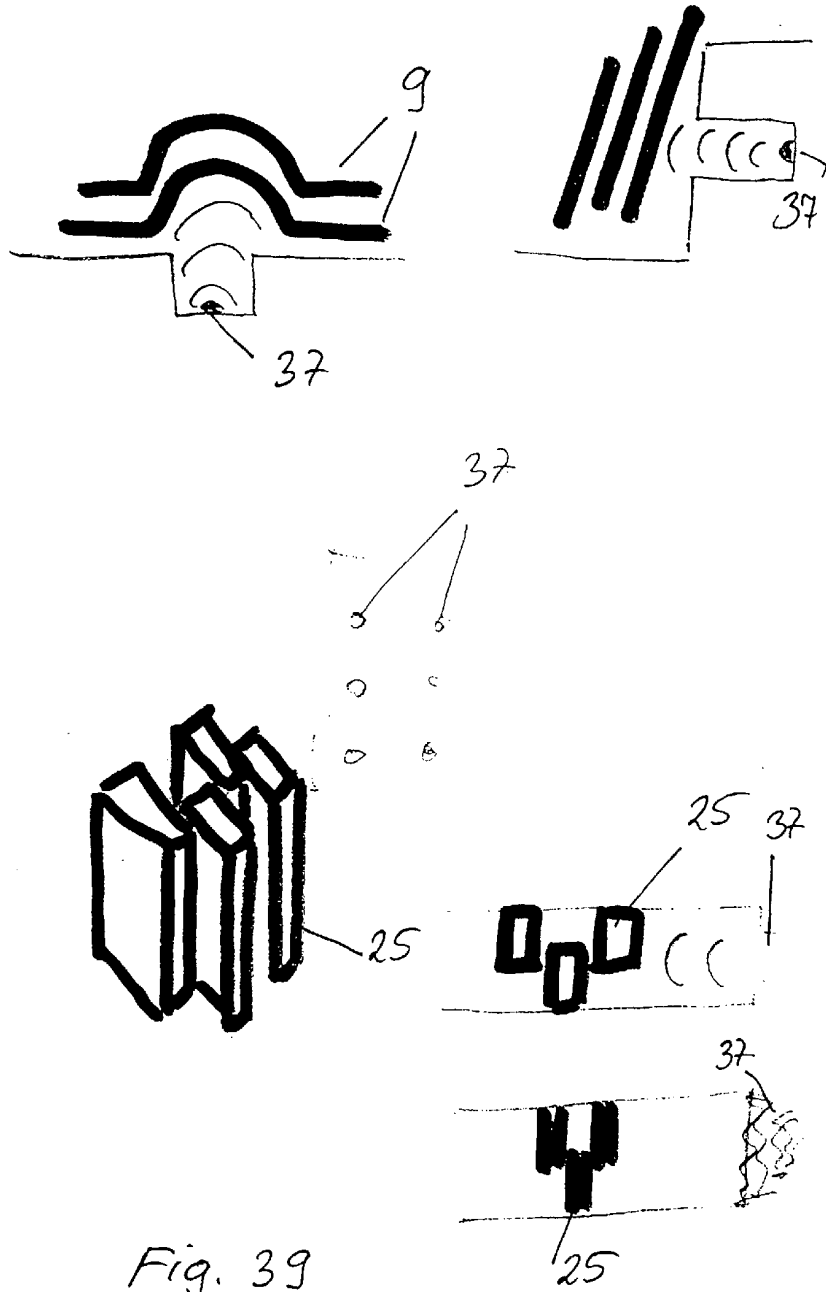

Fig. 39

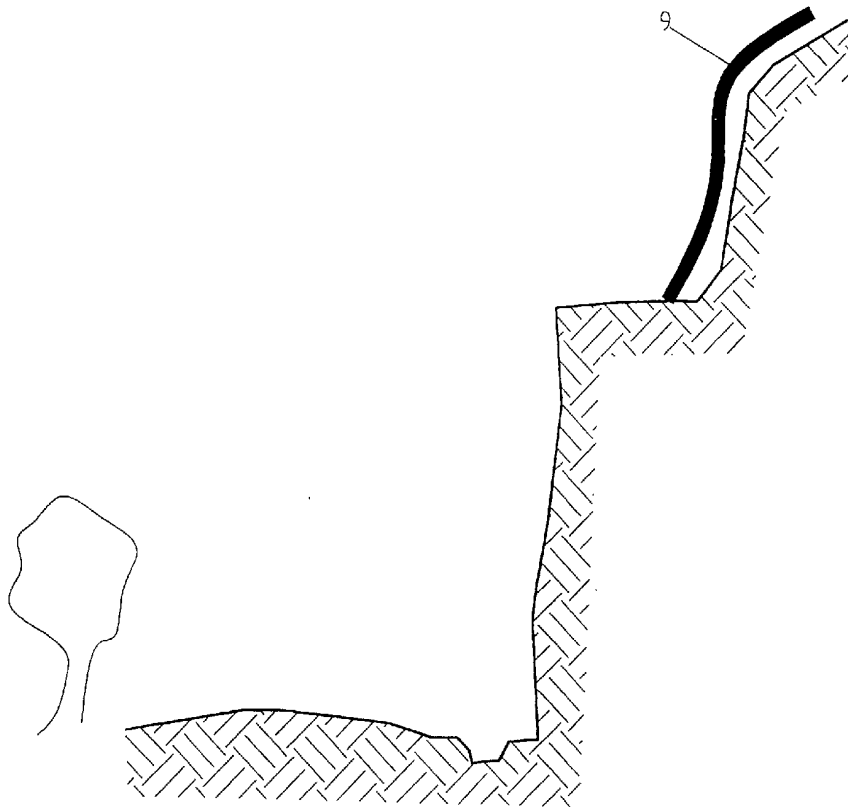

Fig. 40

59/75

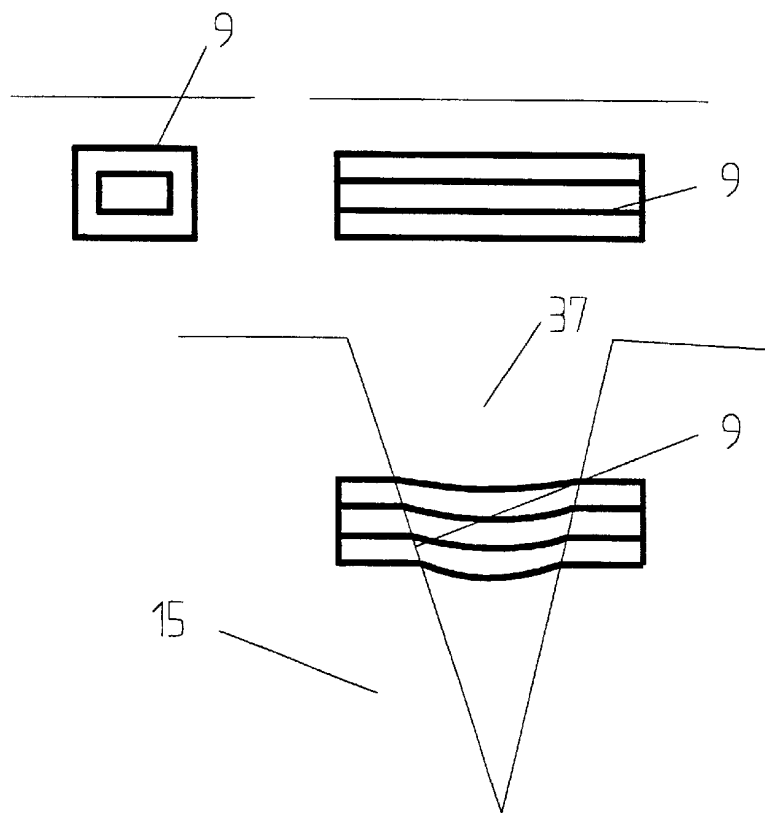

Fig. 41

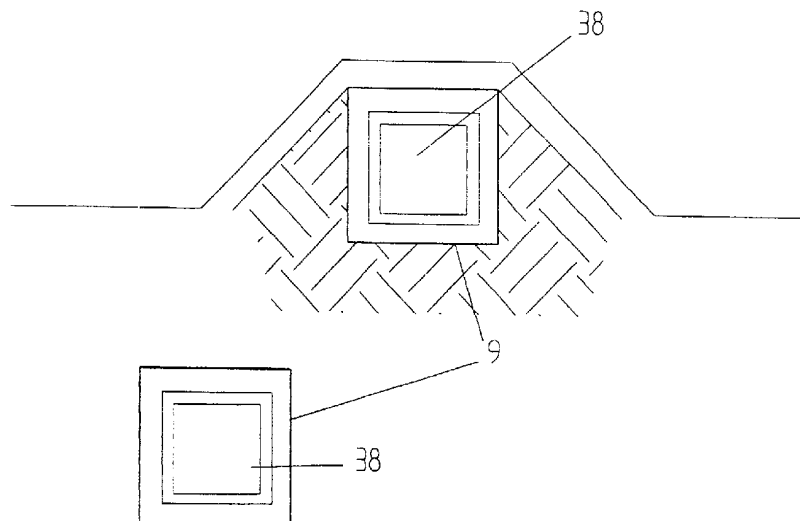

Fig. 42

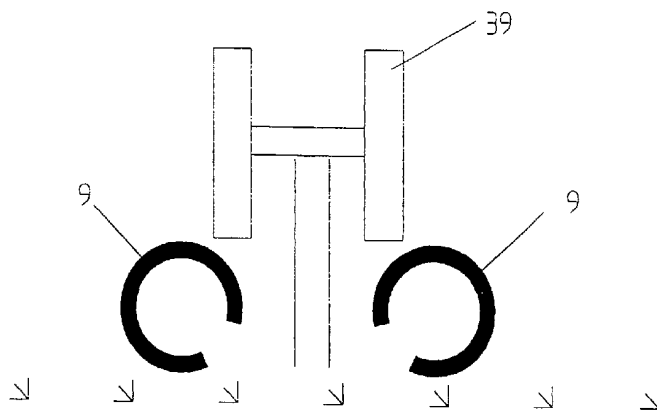

Fig. 43

62/75

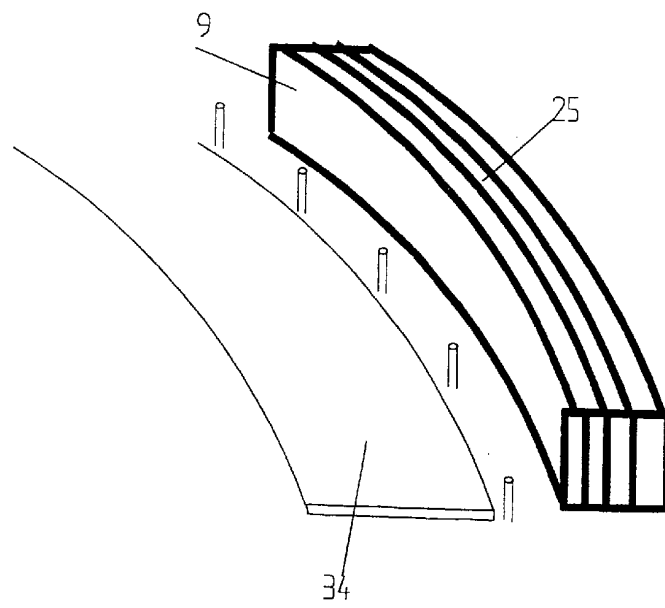

Fig. 44

63/75

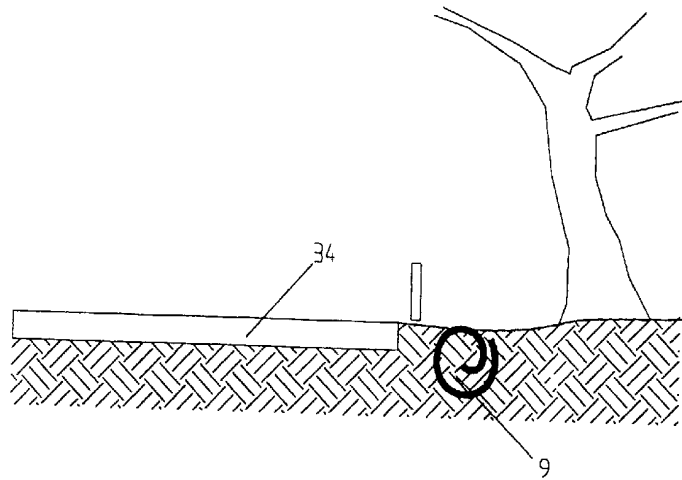

Fig. 45

64/75

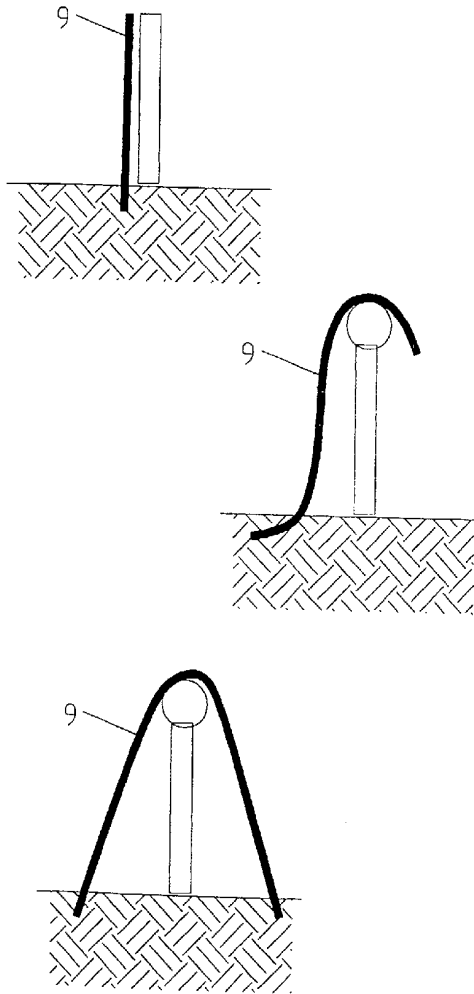

Fig. 46

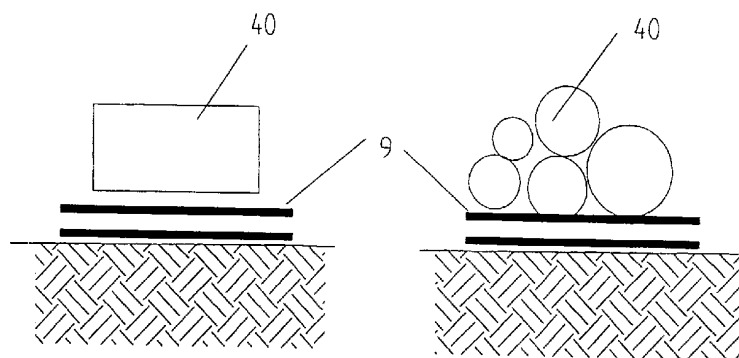

Fig. 47

66/75

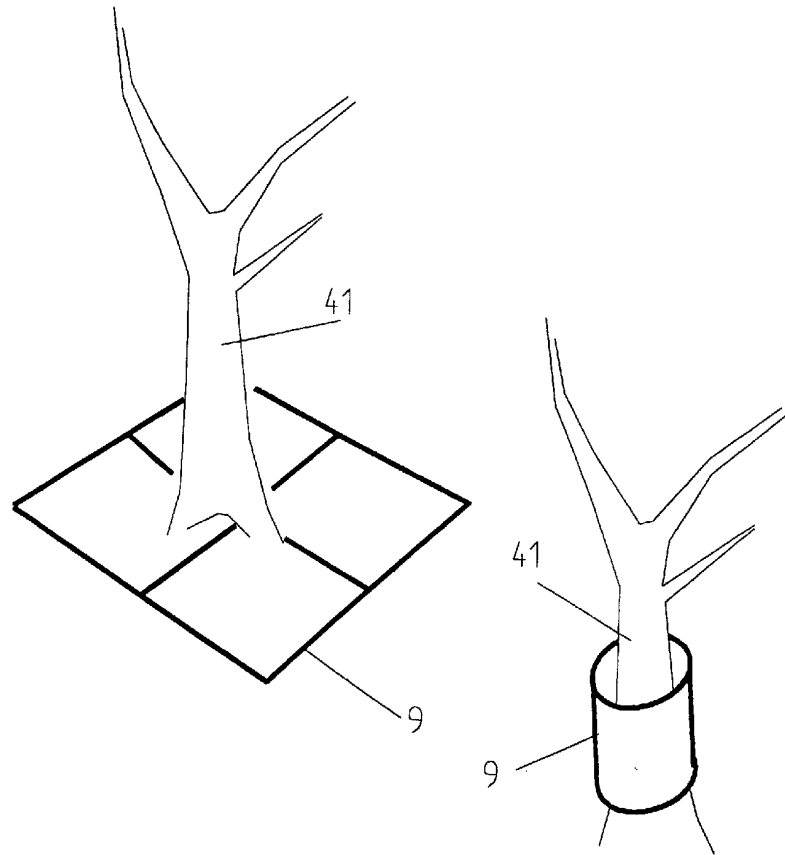

Fig. 48

ERSATZBLATT (REGEL 26)

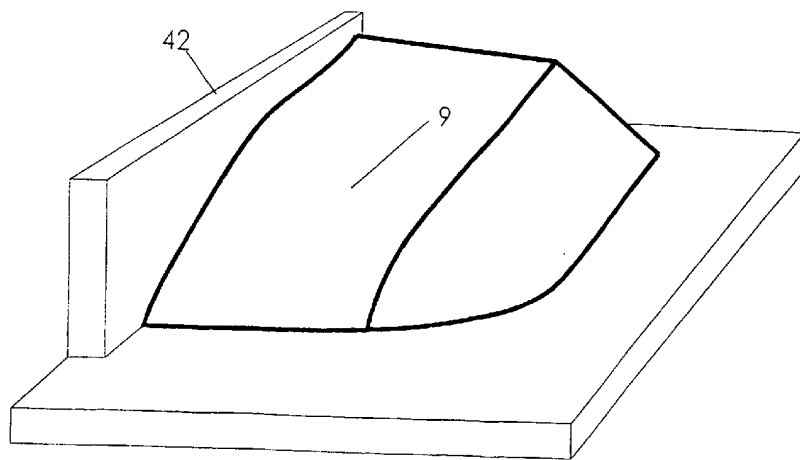

Fig. 49

ERSATZBLATT (REGEL 26)

68/75

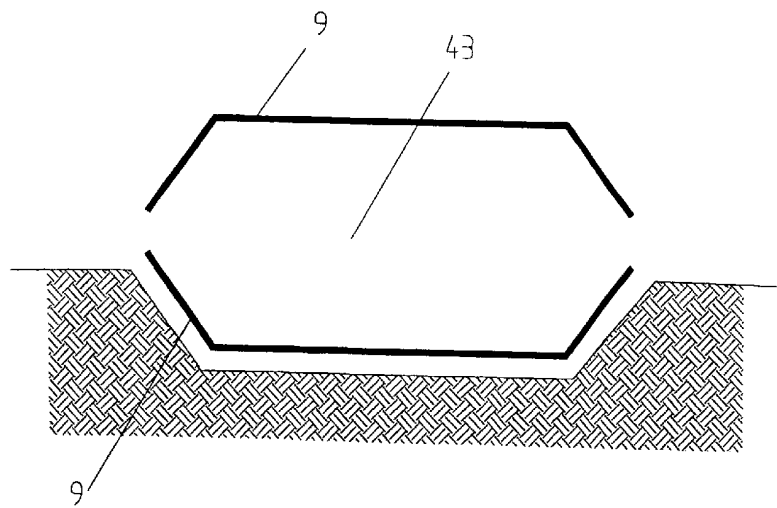

Fig. 50

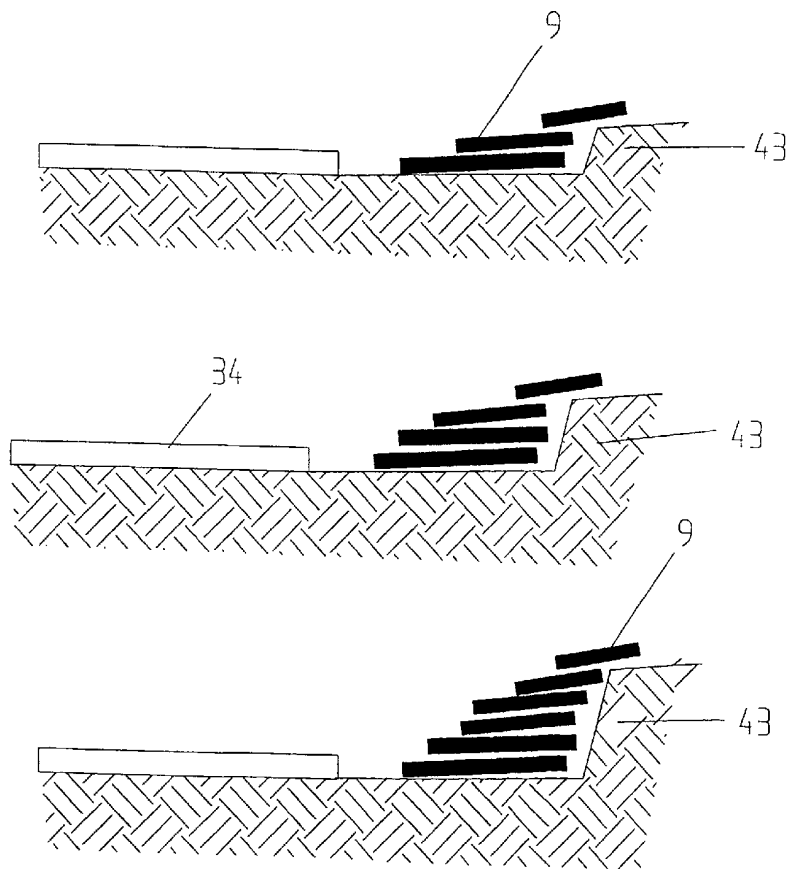

Fig. 51

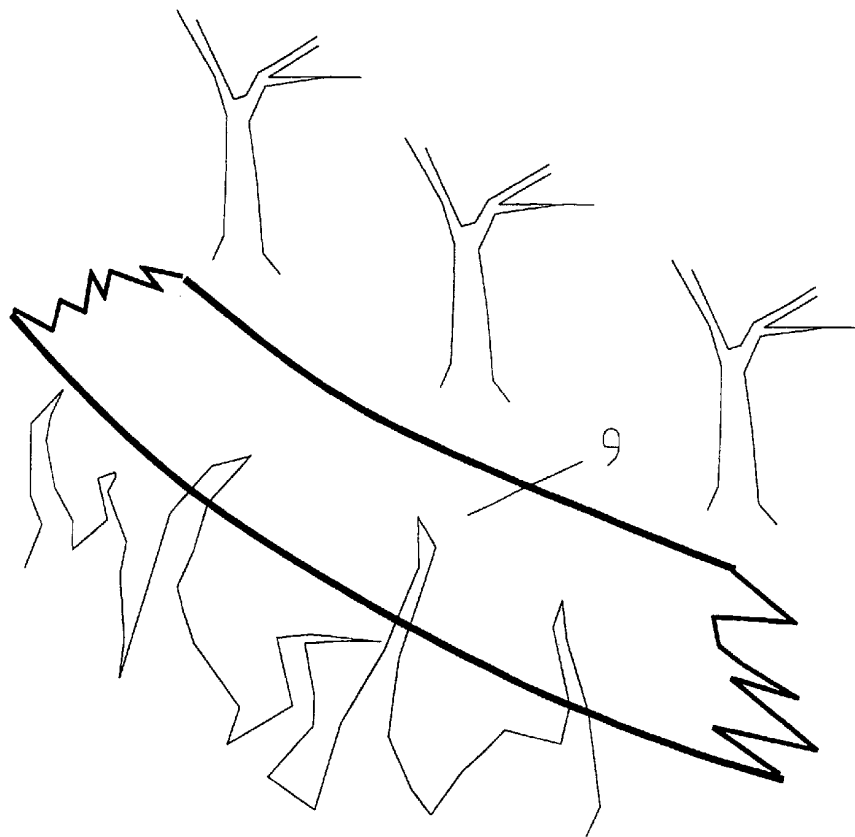

Fig. 52

71/75

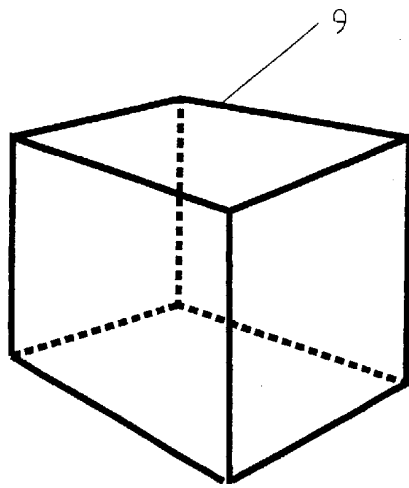

Fig. 53

72/75

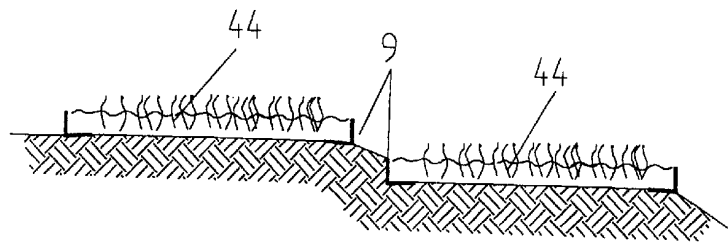

Fig. 54

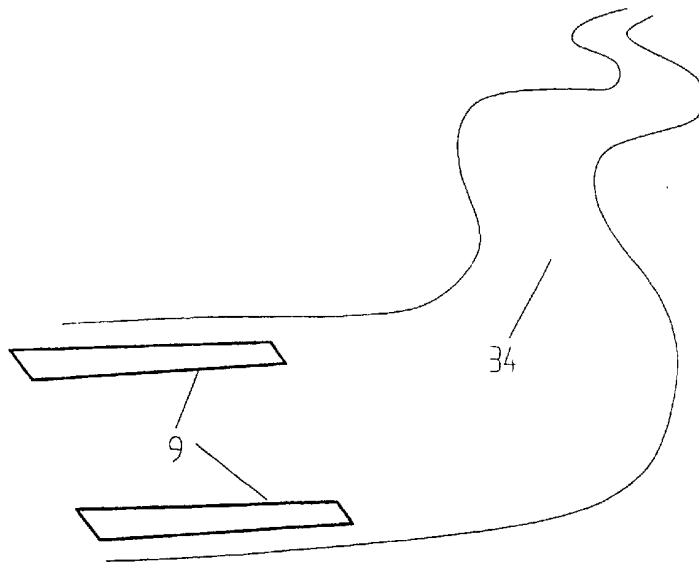

Fig. 55

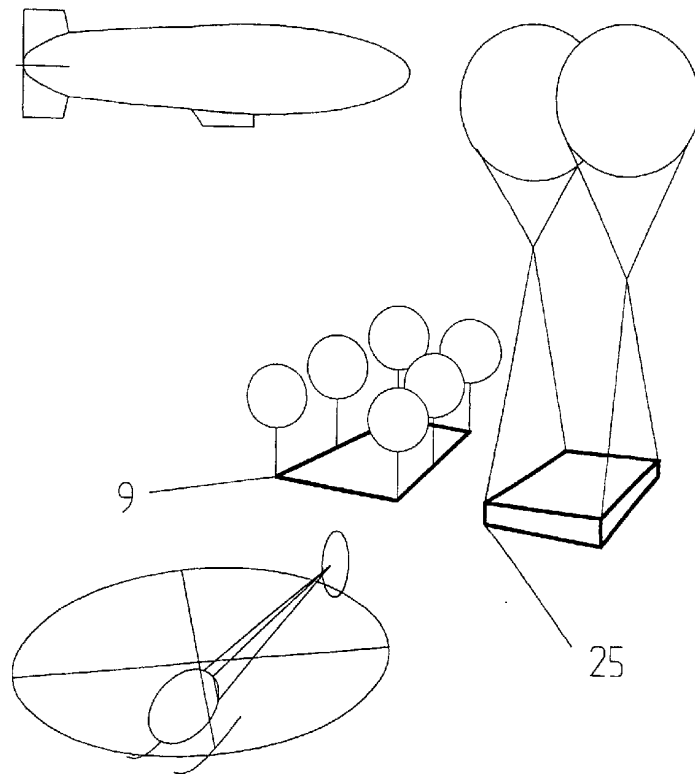

Fig. 56

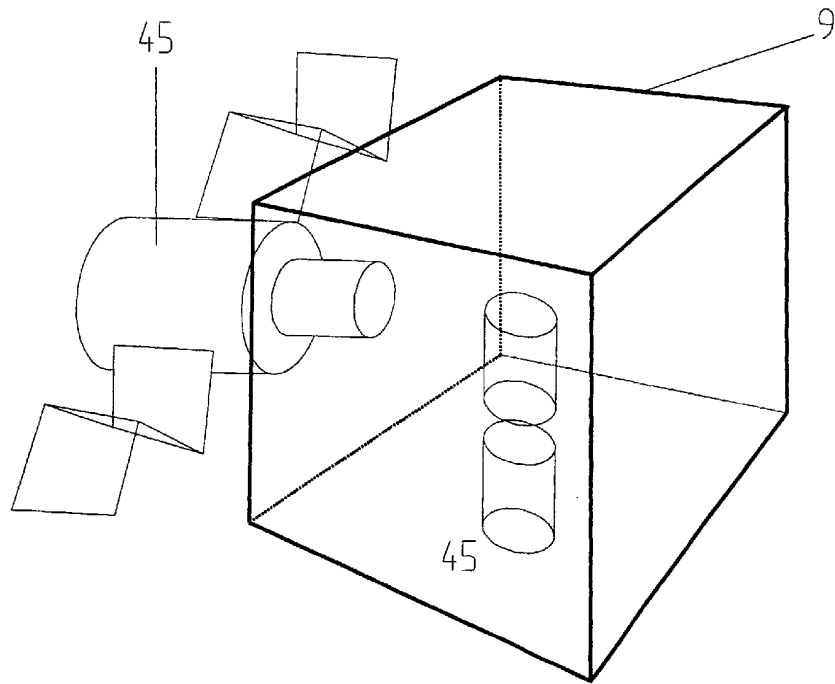

Fig. 57